

I Application

Filters have a wide range of applications in the food-processing, cosmetics and some chemical industries as well as in auxiliary services of the pharmaceutical industry. They have a hygienic design and are used to filter particles capable of damaging pumps and other equipment.

I Operating principle

The filter basically consists of a filter body with an inlet and an outlet for the product. The screen is fixed inside the body. The screen retains all particles that are equal or larger than the size of the screen openings.

I Design and features

There are several configurations:

- Cleaning of the screen **without disassembling the filter**:

Angular filter (82700): the inlet and the outlet form a right angle.

Y filter (83700): the product enters and leaves the filter in the same direction.

- Cleaning of the screen **disassembling the filter**:

Straight filter (81700): the product enters and leaves the filter in the same direction.

Low pressure drops.

DIN 11850 standard connections.

Screen with circular (from \varnothing 0,5 mm to \varnothing 3 mm) or longitudinal openings (10 x 1 mm).

3A certified filters.

I Materials

Filter body	AISI316L
Gaskets	EPDM (according to FDA 117.2600)
Internal surface finish	Ra < 0,8 μ m
External surface finish	mirror polish

I Options

Gaskets in NBR, MVQ, FMP.

Connections: DIN, Clamp, SMS, RJT, FIL-IDF, etc.

Wedge wire screen cylinder.

Heating jacket.

Option of filtering from outside to inside of the screen.

Double filter.



I Technical specifications

Available sizes	DN 25 - DN 150	1" - 6"
Working temperature	-10 °C to +120 °C (EPDM)	14 °F a 248 °F
	+140 °C (SIP, max. 30 min)	284 °F
Max. working pressure	10 bar	145 PSI

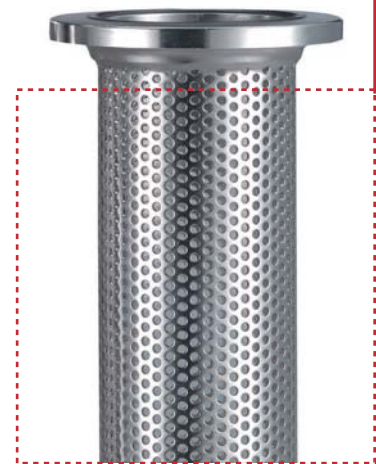

SCREEN: WEDGE WIRE

Mesh equiv.	C (mm)	Useful surface (%)
40	0,40	28
60	0,30	23
80	0,20	17
165	0,10	10
325	0,05	5

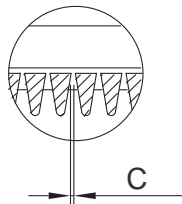

SCREEN: PERFORATED PLATE

A (mm)	Useful surface (%)
0,5	15
1	28
2	30
5	46
10x1	20

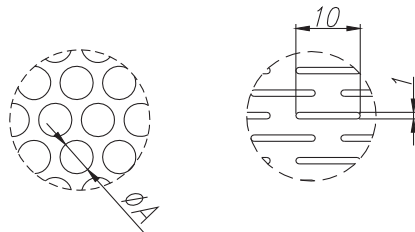

I Dimensions

STRAIGHT FILTER (81700)

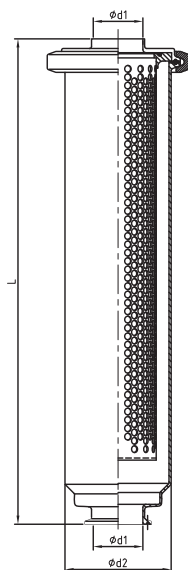

WELD / CLAMP DIN			
DN	d1	d2	L
25	26	76,2	386
32	32		
40	38	101,6	472
50	50		
65	66	114,3	648
80	81		
100	100	154	798
125	125	219,1	1032
150	150		

WELD / CLAMP OD			
DN	d1	d2	L
1"	22,1	76,2	377
1½"	34,8	101,6	462
2"	47,5		
2½"	60,2	114,3	637
3"	72,9		
4"	97,4	154	784
5"	123	219,1	1004
6"	146,8		



The information contained in this brochure is for guidance only. We reserve the right to modify any material or feature without notice in advance. For further information, please, consult our web site. www.inoxpa.com



I Dimensions

ANGULAR FILTER (82700)

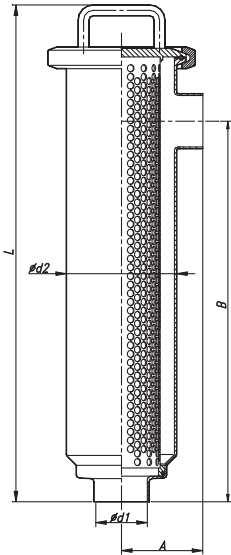

WELD / WELD DIN					
DN	d1	d2	A	B	L
25	26	76,2	70	300	400
32	32		78		
40	38	101,6	100	370	485
50	50		110		
65	66	114,3	120	525	665
80	81		145		
100	100	154	155	675	825
125	125	219,1	175	912	1088
150	150				

WELD / WELD OD					
DN	d1	d2	A	B	L
1"	22,1	76,2	65	300	400
1½"	34,8	101,6	85	370	485
2"	47,5		110		
2½"	60,2	114,3	135	525	665
3"	72,9		155		
4"	97,4	154	195	675	825
6"	146,8	219,1	220	920	1100

I Pressure loss

	ANGULAR FILTER Kv										
	Wedge wire screen					Perforated plate screen					
	0,05	0,1	0,2	0,3	0,4	10x1	0,5	1	2	2,5	5
DN 25	19,8					20,5					
DN 32	33,1					36,8					
DN 40	46,3					47,3					
DN 50	68,4					76					
DN 65	82,6	99,9	107,1	108,5	111,9	122,3					
DN 80	86,5	128,9	136,4	140,9	148,9	160,8					
DN 100	108,8	167,6	192,7	204,8	227,9	287,6					
1"	14,5					16,1					
1½"	33,9					35,6					
2"	59,4					68,9					
2½"	72,3	78,2	81,1	81,4	84,3	86					
3"	85,2	106,6	107,9	114,5	120,1	134,2					
4"	92,8	169,5	186,4	195,5	212,8	273,3					

Tests performed at 20°C. Values are valid for fluids with viscosity and density similar to water.

Formula for pressure loss calculation: $\Delta p = \left(\frac{Q}{K_v}\right)^2$ Kv = Kv value from the above table
Q = flow rate [m³/h]
Δp = pressure [bar]



The information contained in this brochure is for guidance only. We reserve the right to modify any material or feature without notice in advance. For further information, please, consult our web site. www.inoxpa.com



I Dimensions

Y FILTER (83700)

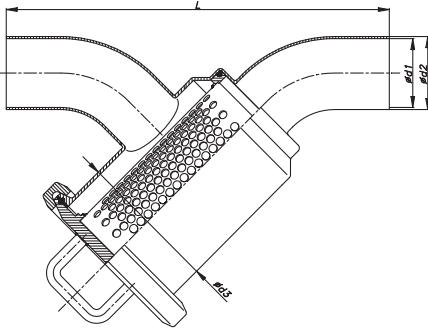

WELD / WELD DIN				
DN	d1	d2	d3	L
25	26	29	76,2	235
32	32	35		240
40	38	41	101,6	260
50	50	53		280
65	66	70	114,3	320
80	81	85		375
100	100	104	154	400
125	125	129	219,1	665
150	150	154		719

WELD / WELD OD				
DN	d1	d2	d3	L
1"	22,1	25,4	76,2	213
1½"	34,8	38,1	101,6	242
2"	47,5	50,8		300
2½"	60,2	63,5	114,3	348
3"	72,9	76,2		378
4"	97,4	101,6	154	468
6"	146,8	152,4	219,1	652,7

I Pressure loss

	Y FILTER Kv										
	Wedge wire screen					Perforated plate screen					
	0,05	0,1	0,2	0,3	0,4	10x1	0,5	1	2	2,5	5
DN 25	16					18					
DN 32	22,3					27,4					
DN 40	33,5					35,3					
DN 50	53,3					55,8					
DN 65	68,8	88,1	91,1	96,2	*	103,6					
DN 80	75,6	113,5	120	124,7	*	135					
DN 100	*	153,2	*	*	*	234					
1"	12,6					13,9					
1½"	29					29,5					
2"	50,1					53,8					
2½"	60	73,4	77,5	80,3	*	81,6					
3"	61,1	97,1	102,4	107,3	*	109,9					
4"	*	141,9	*	*	*	220,8					

* To be consulted

Tests performed at 20°C. Values are valid for fluids with viscosity and density similar to water.

Formula for pressure loss calculation: $\Delta p = \left(\frac{Q}{K_v}\right)^2$

$K_v = K_v$ value from the above table

$Q =$ flow rate [m³/h]

$\Delta p =$ pressure [bar]



The information contained in this brochure is for guidance only. We reserve the right to modify any material or feature without notice in advance. For further information, please, consult our web site. www.inoxpa.com

