



## INSTALLATION, SERVICE AND MAINTENANCE INSTRUCTIONS

# CHECK VALVE



### **INOXPA, S.A.**

c/Telers, 54 Apto. 174

E-17820 Banyoles

Girona (Spain)

Tel. : (34) 972 - 57 52 00

Fax. : (34) 972 - 57 55 02

Email: [inoxpa@inoxpa.com](mailto:inoxpa@inoxpa.com)

[www.inoxpa.com](http://www.inoxpa.com)

Certificado ISO 9001 por



CE



## EC DECLARATION OF CONFORMITY

Manufacturer: INOXPA, S.A.  
C/ Telers, 54  
17820 Banyoles (Girona) - SPAIN

Hereby declares, that the product:

<u>VALVE</u>	<u>CHECK - 72700</u>	<u>2008</u>
Name	Type	Year of manufacture

conforms to the specifications of the Council Directive:

**Pressure Equipment Directive 97/23/CE**, the equipment has been designed and manufactured in accordance with the requirements of the Directive.

**Max operating P.:** DN-25/1" to DN-100/4" = 10 bar

**Diameter:** DN-25

**Equipment category:** SEP = Sound Engineering Practice, determined according to Article 3 Section 1.3.a, first paragraph Annex II, Table 6

**This material SHALL NOT carry CE marking.**

**Diameter:** DN-25 < X < 6 = DN-100

**Equipment category:** Category I, determined according Article 3 Section 1.3.a, first paragraph Annex II, Table 6

**This material SHALL carry CE marking.**

**Conformity Assessment Module:** Module A

In compliance with the Regulations **(CE) n° 1935/2004**, relating to materials and articles intended to come into contact with foodstuff (repeal Directive 89/109/CEE), the materials in contact with the product do not transfer their components in quantities which may jeopardise consumer's health or safety.

**Declaration of Incorporation** (Directive 98/37/CE, annex II, part B):

**The equipments above mentioned won't put to operation till the machine into or onto it will be installed must comply with the stipulations of the Machine Directive.**

Banyoles, March 2008

  
Marc Pons Bague Technical Manager

# 1. Safety

## 1.1. INSTRUCTION MANUAL

This instruction manual contains basic indications which should be fulfilled during the installation, starting and maintenance. The information published in the instruction manual is based on updated information. INOXPA reserves the right to modify this instruction manual without prior notice.

## 1.2. START-UP INSTRUCTIONS

This instruction manual contains essential useful information to handle and maintain your valve appropriately. Not only should the safety instructions indicated in this chapter be observed and fulfilled, but so should the special measures and recommendations included in the other chapters of this manual. These instructions should be kept in a safe location near the installation.

## 1.3. SAFETY

### 1.3.1. Warning symbols.



General danger of injury



Danger of injuries caused by the rotary parts of the equipment



Electrical hazard



Danger! Caustic or corrosive agents.



Danger! Suspended loads



Danger for the correct operation of the equipment.



Compulsory requirement to ensure safety at work



Use of goggles is compulsory.

## 1.4. GENERAL SAFETY INSTRUCTIONS



Read the instruction manual carefully before installing and starting up the valve. Contact INOXPA in case of doubt

### 1.4.1. During the installation.



The *Technical Specifications* of Chapter 8 should always be observed.

The installation and use of the valve should always be carried out in accordance with applicable regulations regarding health and safety.

Before starting up the valve, verify that the assembly is correct and that the shaft is perfectly aligned. An incorrect alignment and/or excessive force in securing the valve may cause serious mechanical problems in the valve.

### 1.4.2. During operation.



The *Technical Specifications* of Chapter 8 should always be observed. Under no circumstances can the limit values specified be exceeded.



NEVER touch the valve and/or the tubes in contact with the liquid during operation. You risk being burnt if you work with hot products.



The valve contains parts operating in linear movement. Do not place your hands or fingers in the valve-closing area. This may cause serious injury.

#### 1.4.3. During maintenance



The *Technical Specifications* of Chapter 8 should always be observed.

**NEVER** disassemble the valve until the pipes have been emptied. Bear in mind that the liquid in the pipe may be dangerous or extremely hot. Consult the regulations in effect in each country for these cases.

Do not leave parts loose on the floor.



All electrical work should be carried out by authorised personnel.

#### 1.4.4. In compliance with the instructions.

Any non-fulfilment of the instructions may result in a risk for the operators, the environment and the machine, and may result in the loss of your right to claim damages

This non-fulfilment may result in the following risks:

- Failure of important functions of the machines/plant.
- Failure of specific maintenance and repair procedures.
- Possibility of electric, mechanical and chemical risks.
- Will place the environment in danger due to the release of substances.

#### 1.5. GUARANTEE.

Any guarantee will be cancelled immediately and as a matter of law and, in addition, we will require compensation for any claims of civil liability presented by third parties, if:

- The installation and maintenance work has not been carried out according to the instructions of this manual.
- The repairs are not carried out by our personnel or have been carried out without our written authorisation.
- The parts used are not INOXPA original parts.
- Modifications have been carried out on our materials without written authorisation.
- The material has been badly used, incorrectly used, or used with negligence or has not been used according to the indications and intended use specified in this manual.

The general conditions of delivery already in your possession are also applicable.

Please do not hesitate to contact us in case of doubts or more complete explanations are required on specific data (adjustments, assembly, disassembly, etc.).

## 2. Table of contents

<b>1. Safety</b>	
1.1. Instruction Manual .....	3
1.2. Start-Up instructions .....	3
1.3. Safety .....	3
1.4. General safety instructions.....	3
1.5. Guarantee. ....	4
<b>2. Table of contents</b>	
<b>3. Receiving and Installation</b>	
3.1. Check the Shipment .....	6
3.2. Delivery and unpacking .....	6
3.3. Identification .....	6
3.4. Location .....	7
3.5. Assembly .....	7
3.6. Inspecting and Checking.....	7
3.7. Welding.....	7
<b>4. Start-Up</b>	
4.1. Start-Up .....	9
4.2. Operation .....	9
<b>5. Operating problems: Causes and solutions</b>	
<b>6. Maintenance</b>	
6.1. General Information .....	11
6.2. Maintenance .....	11
6.3. Cleaning .....	12
<b>7. Assembly and disassembly</b>	
7.1. Disassembly / Assembly of the Check Valve.....	13
7.2. Check Valve Position .....	13
<b>8. Technical Specifications</b>	
8.1. Weld / Weld Check Valve Dimensions.....	15
8.2. Section and Part List .....	16
8.3. Spare Parts.....	16

# 3. Receiving and Installation

## 3.1. CHECK THE SHIPMENT

The first thing to do on receiving the valve is to verify that it matches the delivery slip. INOXPA will inspect all the equipment before packing, although it cannot guarantee that the merchandise will arrive intact to the user. For this reason, the valve received and any other article should be checked and, if it is found not to be in good condition and/or not all parts are included, the carrier should submit a report as soon as possible. Each valve has a manufacturing number engraved. Indicate the manufacturing number in all documents and correspondence.

## 3.2. DELIVERY AND UNPACKING



**INOXPA will not be responsible for the inappropriate unpacking of the valve and its components.**

### 3.2.1. Delivery:

Check that all the parts indicated in the delivery slip exist

- Complete valve.
- Its components (if supplied).
- Delivery slip.
- Instruction manual.

### 3.2.2. Unpacking:

Remove all traces of packing materials from the valve or parts. Inspect the valve or its constituent parts for possible damage caused during transport. Avoid any possible damage to the valve and its components.

## 3.3. IDENTIFICATION

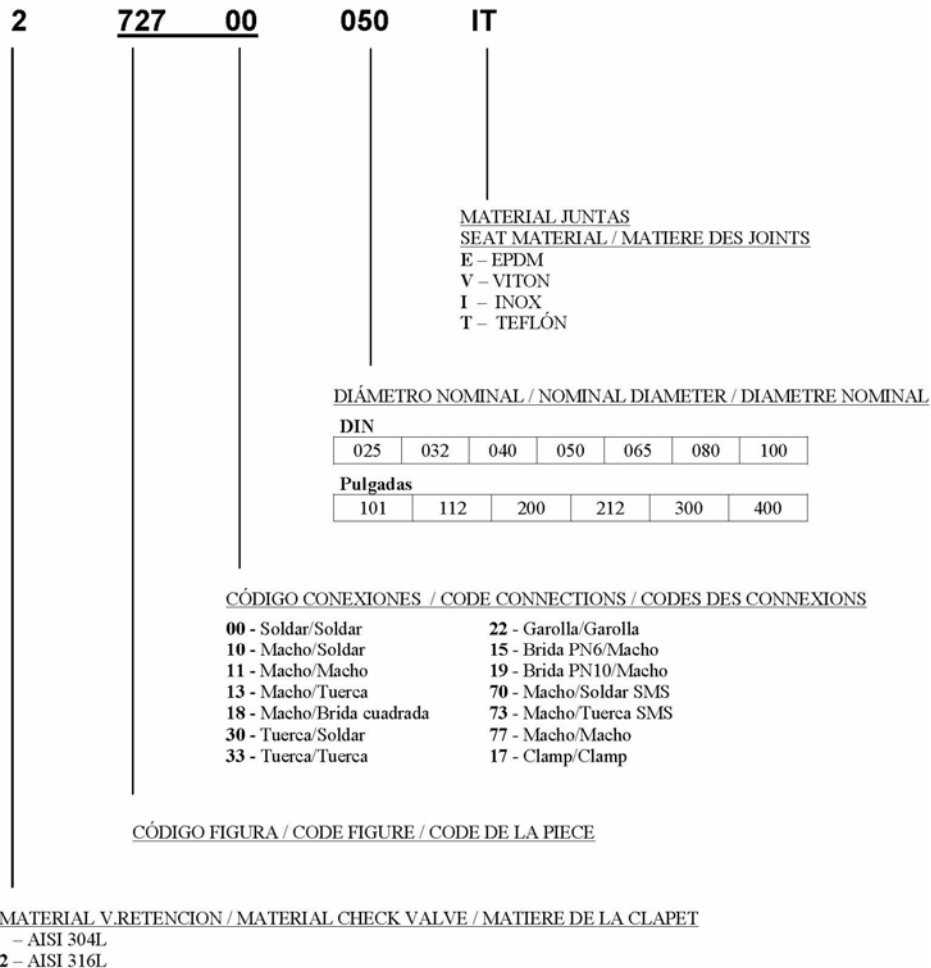



**The buyer or user will be responsible for the assembly, installation, starting and operation of the valve.**

### 3.4. LOCATION

Place the valve in such a way as to facilitate inspections and checks. Leave sufficient space around the valve for appropriate inspection, separation and maintenance (See Section 3.7.3).

### 3.5. ASSEMBLY

Once the location of the valve is established, the pipe can be connected by welding the valve body and cover or by means of accessories (connectors). The check valve must be installed vertically and in the direction of the flow.

Excessive stress should be avoided during the assembly of the valves and special attention should be given to the following:

- Vibration which may be produced in the installation.
- Expansion of the pipes during circulation of hot liquids.
- The weight that the pipes can withstand.
- Excessive intensity of welding.

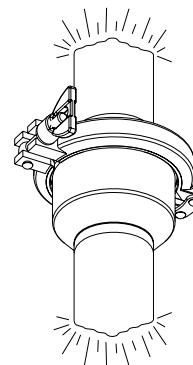

### 3.6. INSPECTING AND CHECKING

Check the following before use:

- Open and close the valve several times to ensure that it operates correctly and check that the shaft seal fits smoothly with the valve body.

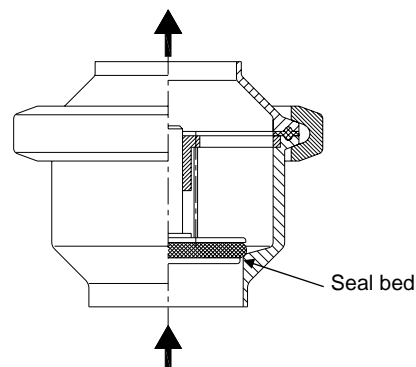

### 3.7. WELDING



**The welding work can only be carried out by persons qualified, trained and equipped with the necessary means to carry out this work.**

**Disassemble the valve before starting the welding work.**

### 3.7.1. Weld/weld check valve. Fig. 72700.

Disassemble the valve as indicated in the *Disassembly* section.

Weld the valve body and cover to the tubes.

On welding the valve body and cover, check that they can be axially separated (See elevation A) in order to disassemble the internal parts of the valve (gasket, shaft, guide bush, spring).

DN	A
25-1"	38
32	39
40-1 1/2"	45
50-2"	50
2 1/2"	58
65	63
3"	63
80	69
100-4"	78

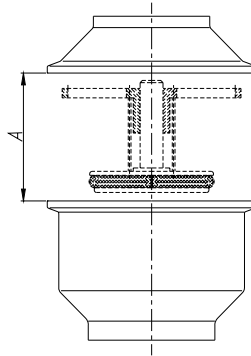

If the valve is connected using accessories (connectors), then elevation A may be much lower.

DN	A
25-1"	2
32	3
40-1 1/2"	3
50-2"	5
2 1/2"	5
65	5
3"	5
80	5
100-4"	10

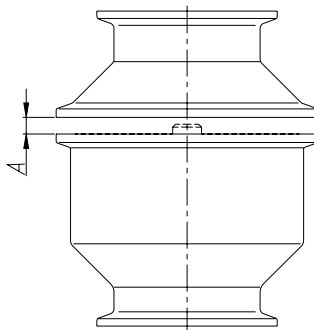

## 4. Start-Up

The start-up of the valve can be carried out if the instructions indicated in Chapter 3 – *Receiving and Installation* are followed.

### 4.1. START-UP



**Before start-up, the responsible persons should be duly informed of the operation of the valve and the safety instructions to be followed. This instruction manual should be available to personnel at all times.**

The following should be taken into consideration before starting-up the valve:

Check that the pipe and valve are completely free from any traces of welding or other foreign matter. Carry out the cleaning of the system if required.

Verify the smooth operation of the valve. If necessary, lubricate with special grease or soapy water.

Check for possible leaks and check that all the pipes and connections are watertight and free from leaks.

Operate the valve.

### 4.2. OPERATION



**Do not modify the operating parameters for which the valve has been designed without written prior authorisation from INOXPA.**



**Danger of burns! Do not touch the valve or pipes when hot liquids are circulating or when cleaning and/or sterilisation are being carried out.**

## 5. Operating problems: Causes and solutions

PROBLEM	CAUSE/EFFECT		SOLUTION
<b>EXTERNAL LEAK. THE PRODUCT IS LEAKING FROM THE CLAMP</b>	The joining seal is worn out or deteriorated. Loss of water-tightness		<ul style="list-style-type: none"> <li>• Replace the seals.</li> <li>• Replace the seals with others of different material and more appropriate for the product.</li> <li>• Tighten the clamp</li> </ul>
<b>INTERNAL LEAK OF THE PRODUCT (VALVE CLOSED)</b>	Premature wearing of the seals		<ul style="list-style-type: none"> <li>• Replace the seals.</li> </ul>
	Premature wearing of the seals	Watertight seal worn or affected by the product. Excessive pressure in the line. Working temperature too high Loss of watertightness (vibration).	<ul style="list-style-type: none"> <li>• Replace the seals with others of different quality, if prematurely deteriorated.</li> <li>• Tighten the weak pieces</li> <li>• Clean frequently</li> </ul>
	Backpressure		<ul style="list-style-type: none"> <li>• Replace the spring with a stronger one.</li> </ul>
<b>VALVE DOES NOT OPEN/CLOSE</b>	Deformation of sealing joint. Spring in poor condition and/or jammed (dirtiness)		<ul style="list-style-type: none"> <li>• Replace the seals with others of different quality, if prematurely deteriorated.</li> <li>• Replace spring and/or shaft (clean).</li> </ul>

\* It is possible for leaks to occur in the stainless-steel/stainless-steel seatings leading to insufficient liquid in the downstream tubes.

# 6. Maintenance

## 6.1. GENERAL INFORMATION

This valve, just like any other machine, requires maintenance. The instructions contained in this manual cover the identification and replacement of spare parts. The instructions have been prepared for maintenance personnel and for those responsible for the supply of spare parts.



Carefully read Chapter 8. *Technical Specifications*.

All replaced material should be duly eliminated/recycled according to the directives in effect in the area.

Assembly and disassembly of the valves must only be carried out by qualified staff.

Before starting on maintenance work, ensure that the tubes are not pressurised.

## 6.2. MAINTENANCE

The following is recommended for appropriate maintenance:

- Regular inspection of the valve and its components.
- Keep a record of the operation of each valve, noting any incidents.
- Always have spare seals in stock.

During maintenance, pay particular attention to the danger indications indicated in this manual.



The valve and pipes should not be pressurised during maintenance.

The valve should not be hot during maintenance. Danger of burns!

### 6.2.1. Maintenance

REPLACEMENT OF SEALS	
Preventive maintenance	Replace after twelve (12) months.
Maintenance after a leak	Replace at the end of the process.
Scheduled maintenance	Regularly check that there are no leaks and that the valve is operating smoothly. Keep a record of the valve. Use statistics to plan inspections.
Lubrication	During assembly, apply lubricants compatible with the seal material. See the following table.

SEAL COMPONENT	LUBRICANT	Class NLGI DIN 51818
NBR/ FPM/ VMQ	Klübersynth UH 1 64-2403	3
EPDM/ NBR/ FPM	PARALIQ GTE 703	3

The time interval between each preventive maintenance may vary according to the working conditions to which the valve is submitted: Temperature, pressure, number of operations per day, type of cleaning solutions used, etc.

### 6.2.2. Storage

Storage of the valves should be carried out in an enclosed area, under the following conditions:

Temperature from 15°C to 30°C

Relative humidity <60%

Open-air storage of the equipment is **NOT** allowed.

### 6.2.3. Spare parts

To request spare parts, it is necessary to indicate the type of valve, the position and the description of the part which can be found in the Technical Specifications chapter.

## 6.3. CLEANING



The use of aggressive cleaning products such as caustic soda and nitric acid may cause burns to the skin.

Use rubber gloves during the cleaning process.



Always use protective goggles.

### 6.3.1. Automatic CIP (cleaning-in-place)

If the valve is installed in a system provided with the CIP process, its disassembly will not be required.

Cleaning solutions for CIP processes.

Only use clear water (chlorine-free) to mix with the cleaning agents:

**a) Alkaline solution:** 1% by weight of caustic soda (NaOH) at 70°C (150°F)

1 Kg NaOH + 100 l. of water = cleaning solution

o

2.2 l. NaOH at 33% + 100 l. of water = cleaning solution

**b) Acid solution:** 0.5% by weight of nitric acid (HNO<sub>3</sub>) at 70°C (150°F)

0.7 litres HNO<sub>3</sub> at 53% + 100 l. of water = cleaning



Check the concentration of cleaning solutions; it may cause the deterioration of the watertight seals of the valve.

To remove any remains of cleaning products, ALWAYS perform a final rinse with clean water on completion of the cleaning process.



Before beginning the disassembly and assembly work, clean the valve inside as well as outside.

### 6.3.2. Automatic SIP (sterilization-in-place)

The process of sterilization with steam is applied to all the equipment including the pigging.



Do NOT start the equipment during the process of sterilization with steam.  
The parts/materials suffer no damage if the indications specified in this manual are observed.

No cold liquid can enter the equipment till the temperature of the equipment is lower than 60°C (140°F).

#### Maximum conditions during the SIP process with steam or overheated water

- |    |                   |  |
|----|-------------------|--|
| a) | Max. temperature: | 140°C / 284°F  |
| b) | Max. time:        | 30 min   |
| c) | Cooling:          | Sterile air or inert gas                                       |
| d) | Materials:        | EPDM / PTFE (recommended)<br>FPM / NBR / VMQ (not recommended) |

# 7. Assembly and disassembly



Proceed with caution. There is danger of personal injury.

Assembly and disassembly of the valves must only be carried out by qualified staff.

## 7.1. DISASSEMBLY / ASSEMBLY OF THE CHECK VALVE

### Assembly

1. Loosen the clamp (23) and remove it from the housing (01) and the cap (22),
2. Separate the cap (22) from the housing (01).
3. Remove the gasket (21) from the body.
4. Remove the guide bush (20), the spring (06), shaft (08) and the shaft gasket (20A)
5. Separate the guide bush, spring, and shaft.
6. Disassemble the toric gasket (20A) from the shaft body.

### Assembly

1. Place the gasket (20A) in the shaft body (08). Lubricate the gasket if necessary.
2. Place the spring (06) on the shaft (08), Take the guide bush (20) and attach it to the shaft / spring.
3. Set the spring, shaft, and bush grouping (06,08,20) into the valve housing (01),
4. Place the gasket (21) on the valve housing.
5. Place the cap (22) over the gasket (21),
6. Place the clamp (23) so that the flanges of the cap (22) and the valve housing (01) are inside the clamp.
7. Tighten the wing nut of the clamp (23).

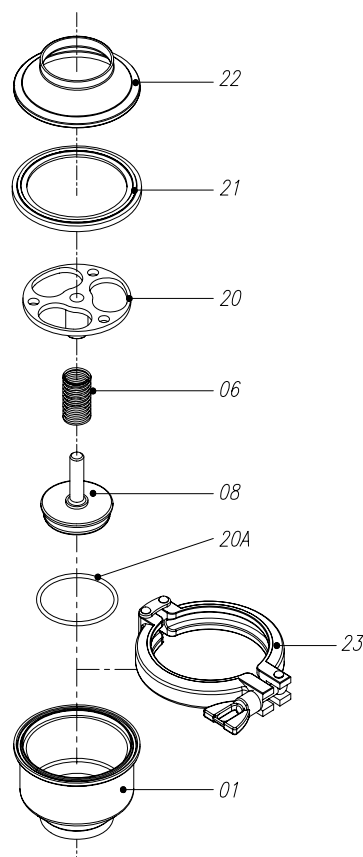

**NO tools are required to disassemble the valve**

## 7.2. CHECK VALVE POSITION

The check valve is designed to be installed in a vertical position, and with the flow direction indicated in this manual.

## 8. Technical Specifications

VALVE GENERAL DATA			
Maximum working pressure	DN-25/100 DN-1"/4" <span style="float: right;">10 bar</span>		
Maximum working temperature	121°C (250°F) EPDM standard seals (Other qualities of seals will be adapted for higher temperatures)		
Opening pressure	DN-25 - 1"	DN-32/40 - 1½"	DN-50/100 - 2"/4"
	0,3bar	0,2bar	0,1bar
Surface finish	In contact with the product: $Ra \leq 0.8 \mu m$ External surfaces: Machined finish (turned on lathe)		

VALVE MATERIALS	
Parts in contact with the media	AISI 316L (1.4404)
Other steel parts	AISI 304 (1.4301)
Gaskets in contact with the media	EPDM (STANDARD) - NBR - VITON - SILICONA.
Surface finish	Parts in contact with the media < $Ra. 0.8\mu m$
Type of connections	DIN 11851 (Standard) Welding, FIL-IDF, BS-RJT, SMS, Clamp, Flanges, Macon.

### 8.1. WELD / WELD CHECK VALVE DIMENSIONS

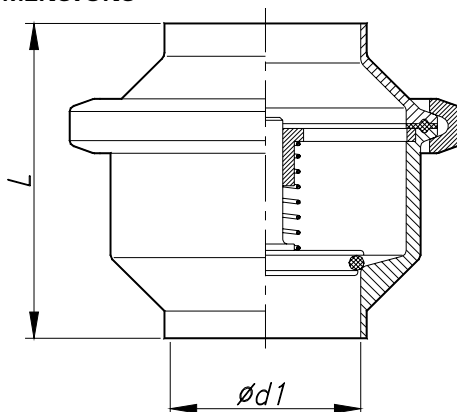

• S/S Fig.72700

DN	d1	L	AISI 316L
1"	22,1	73	272700101E
1 1/2"	34,8	80	272700112E
2"	47,5	85	272700200E
2 1/2"	60,2	110	272700212E
3"	72,9	115	272700300E
4"	97,6	125	272700400E

DN	d1	L	AISI 316L
25	26	73	272700025E
32	32	73	272700032E
40	38	80	272700040E
50	50	85	272700050E
65	66	110	272700065E
80	81	115	272700080E
100	100	125	272700100E

DN	d1	L	AISI 316L
25	26	73	272710025E
32	32	73	272710032E
40	38	80	272710040E
50	50	85	272710050E
65	66	110	272710065E
80	81	115	272710080E
100	100	125	272710100E

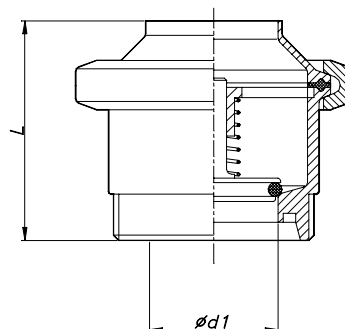

• M/S Fig. 72710

DN	d1	L	AISI 316L
1"	22,1	98	272717101E
1 1/2"	34,8	105	272717112E
2"	47,5	110	272717200E
2 1/2"	60,2	135	272717212E
3"	72,9	140	272717300E
4"	97,6	157	272717400E

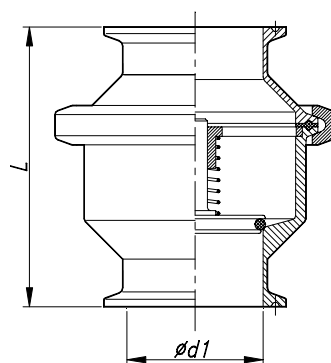

• CL/CL Fig. 72717

## 8.2. SECTION AND PART LIST

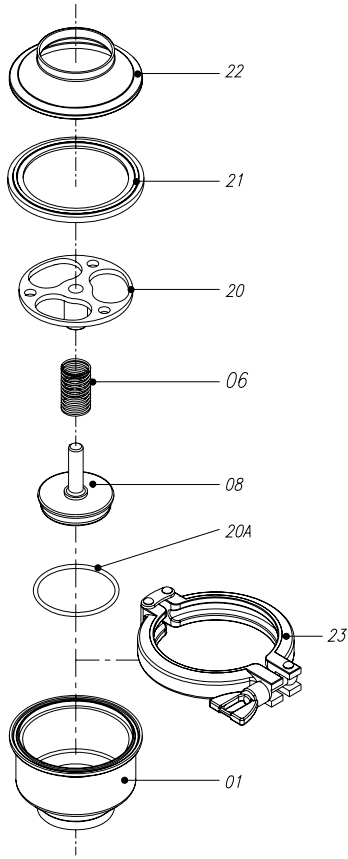

POSITION	DESIGNATION	MATERIAL	QUANTITY
01	Housing	AISI 316L	1
06	Spring	AISI 301	1
08	Shaft	AISI 316L	1
20	Guide bush	AISI 316L	1
20A*	Shaft gasket	EPDM	1
21*	Clamp seal	EPDM	1
22	Cap	AISI 316L	1
23	Clamp	AISI 304	1

## 8.3. SPARE PARTS

DN	01	06	08	20	20A*	21*	22	23
25	451387.6	MU-450489	450486A.6	450836.6	O4020235	1708200	450814.6	1703200
32	451722.6		450486B.6		O4042030		451723.6	
40	451388.6	MU-450490	450486C.6	450837.6	O4032935	1708212	450815.6	1703212
50	451389.6		450486D.6	450838.6	O4040653	1708300	450816.6	1703300
65	451390.6	MU-450491	450486E.6	350318.6	O4056553	1708400	450817.6	1703400
80	350590.6		450486F.6	350319.6	O4072353	1708412	450818.6	1703412
100	350591.6	MU-450492	450486G.6	3503201.6	O4091453	1708512	450819.6	1703512

\* Recommended spare parts .

NOTAS

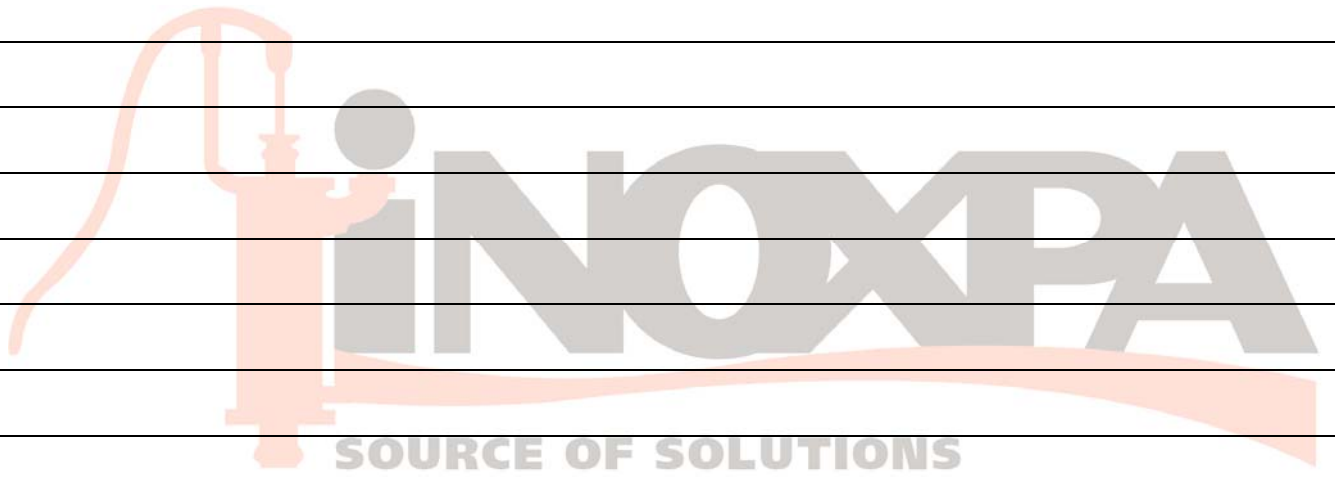



NOTAS

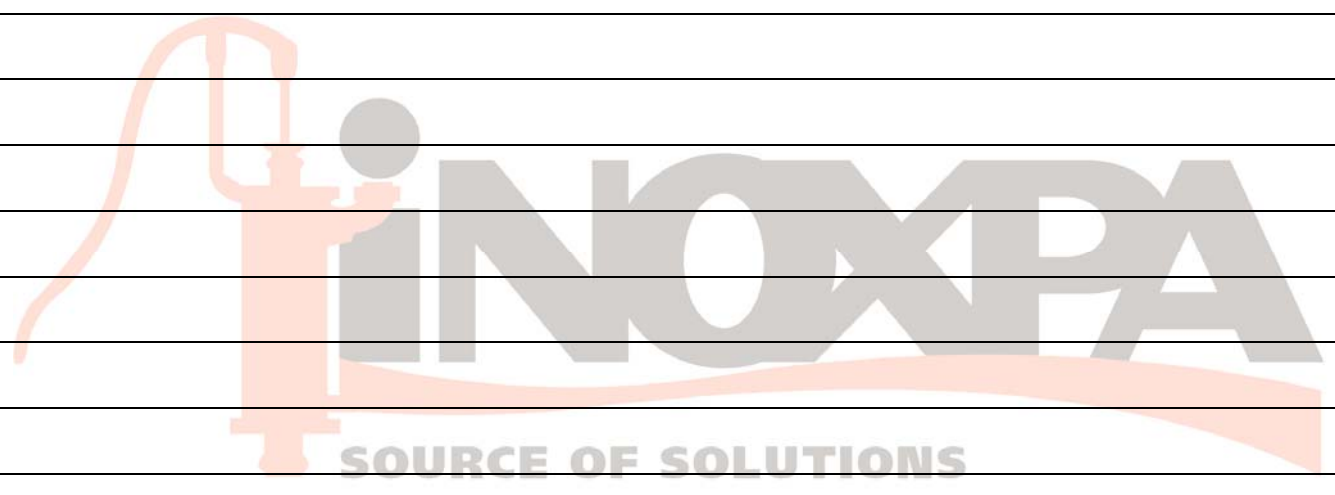

**INOXPA, S.A.**

C/ Telers, 54 - PO Box: 174  
Tel: (+34) 972 575 200  
Email: inoxpa@inoxpa.com

17820 BANYOLES (Girona - Spain)  
Fax: (+34) 972 575 502  
www.inoxpa.com

Gsm: (+34) 667 16 85 20

**BARCELONA – FLUAL, S.L.**

Tel: 937 297 280  
e-mail: flual@inoxpa.com

**MADRID – INOXFLUID, S.L.**

Tel: 918 716 084  
e-mail: inoxfluid@inoxpa.com

**BILBAO – STA, S.L.**

Tel: 944 572 058  
e-mail: sta@inoxpa.com

**VALENCIA – INOXDIN, S.L.**

Tel: 963 170 101  
e-mail: inoxdin@inoxpa.com

**VALLADOLID – ALTAFLUID, S.L.**

Tel: 983 403 197  
e-mail: altafluid@inoxpa.com

**JEREZ – CORFLUID, S.L.**

Tel: 956 140 193  
e-mail: cadiz.corfluid@inoxpa.com

**ZARAGOZA – FLUAL, S.L.**

Tel: 976 591 942  
e-mail: flual.aragon@inoxpa.com

**LA RIOJA – STA, S.L.**

Tel: 941 228 622  
e-mail: sta.rioja@inoxpa.com

**SEVILLA – CORFLUID, S.L.**

Tel: 954 296 852  
e-mail: sevilla.corfluid@inoxpa.com

**CÓRDOBA – CORFLUID, S.L.**

Tel: 957 169 145  
e-mail: jvilchez.corfluid@inoxpa.com

**LA MANCHA – INOXFLUID, S.L.**

Tel: 926 514 190  
e-mail: mancha.inoxfluid@inoxpa.com

**ASTURIAS – STA, S.L.**

Tel: 985 267 553  
e-mail: sta.asturias@inoxpa.com

**INOXPA FRANCE, S.A. - AGENCE NORD**

2, Avenue Saint Pierre  
59118 WAMBRECHIES (France)  
Tel: 33(0)320 631000  
Fax: 33(0)320 631001  
e-mail: inoxpa.nord.fr@inoxpa.com

**AGENCE LYON Z.A.C. D'EPINAY**

69 Allée des Caillotières  
GLEIZE 69400 (France)  
Tel: 33(0)474 627100  
Fax: 33(0)474 627101  
e-mail: inoxpa.fr@inoxpa.com

**AGENCE SUD EST**

Route d'Olonzac  
11200 HOMPS (France)  
Tel: 33(0)468 278680  
Fax: 33(0)468 278681  
e-mail: inoxpa.sud.fr@inoxpa.com

**AGENCE OUEST**

ZA des Roitelières  
44330 LE PALLET (France)  
Tel: 33(0)228 010172  
Fax: 33(0)228 010173  
e-mail: inoxpa.ouest.fr@inoxpa.com

**INOXPA SOLUTIONS FRANCE**

Rue Henri Becquerel  
F - 60230 CHAMBLY (France)  
Tel: 33(0)130289100  
Fax: 33(0)130289101  
e-mail: isf@inoxpa.com

**INOXPA ITALIA S.R.L.**

Via Olivetti, s.n.c., Z.I.  
26010 VAIANO CREMASCO - Cr - (Italia)  
Tel: 39(0)373 791076  
Fax: 39(0)373 791113  
e-mail: inoxpa.it@inoxpa.com

**INOXPA SWEDEN**

Laxfiskevägen 12  
SE-43338 PARTILLE (Sweden)  
Tel: 46 (0) 31 336 05 60  
Fax: 46 (0) 31 336 05 61  
e-mail: inoxpa.se@inoxpa.com

**INOXPA SKANDINAVIEN A/S**

Høegh Guldbergsgade 27  
HORSENS DK-8700 (Denmark)  
Tel: (45) 76 28 69 00  
Fax: (45) 76 28 69 09  
e-mail: inoxpa.dk@inoxpa.com

**INOXPA SOUTH AFRICA (PTY) LTD**

PO Box 782  
7435 MILNERTON – CAPE TOWN  
(Republic of South Africa)  
Tel: 27(0)11 796 5170  
Fax: 27(0)11 796 5172  
e-mail: sales@inoxpa.com

**S.T.A. PORTUGUESA LDA.**

Zona Industrial - Lugar do Guardal  
ALGERIZ. 3730-266 VALE DE CAMBRA  
(Portugal)  
Tel: 351 256 472722  
Fax: 351 256 425697  
e-mail: comercial.pt@inoxpa.com

**INOXPA POLAND sp z o.o.**

Ul. Arkonska, 54  
80-392 Gdansk  
(Poland)  
Tel. 48 58 511 00 05  
Fax 48 58 556 72 51  
e-mail: inoxpa.pl@inoxpa.com

**INOXPA USA, Inc**

3715 Santa Rosa Avenue Suite A4  
Santa Rosa, CA95407  
(California)  
Tel: 1 707 585 3900  
Fax: 1 707 585 3908  
e-mail: inoxpa.us@inoxpa.com

**INOXPA DEUTSCHLAND GMBH**

Kohlhammerstrasse, 6  
D - 70771 LEINFELDEN  
DEUTSCHLAND  
Tel: 49 711 758 59 73  
Fax: 49 71175859750  
e-mail: [rwaidelich.de@inoxpa.com](mailto:rwaidelich.de@inoxpa.com)

**INOXPA REALM LTD**

Gladstone Road  
CROYDON, SURREY  
CR0 28BQ  
Tel: 44 2086895521  
Fax: 44 2086890245  
e-mail: inoxpa-realm@inoxpa.com

**INOXRUS**

Ulitsa Verjnaya 4, Parnas  
194292 Saint Petersburg  
Russia  
Tel: 7 812 622 16 26  
Fax: 7 812 622 19 26  
e-mail: spb@inoxpa.com

In addition to our branch offices, INOXPA operates with an independent distributor network which encompasses a total of more than 50 countries throughout the world.

For more information, please, consult our web page:

[www.inoxpa.com](http://www.inoxpa.com)

This information is for guidance only. We reserve the right to modify any material or feature without notice in advance.