



I Application

The NLR valve is a proportional pneumatically actuated valve designed for flow control in installations of the pharmaceutical industries.

It is widely used to control the pressure of a water loop with a pressure transmitter (PID) when the loop is controlled by neither a flowmeter nor a frequency converter of the pump.

I Operating principle

The position sensor instantly controls the operating position to keep the valve in the position determined by the user (PD function) or by a process parameter (PID function). The operation position can be programmed by:

- a standard input signal sent by an external element (e.g. a sensor).
- an internal controller integrated into the positioner. The signal is sent from a keyboard.

I Diseño y características

Sanitary design according to 3A standards.

Normally closed valve (standard version).

Equal percentage regulation shaft.

360° adjustable body.

Compact design.

Dual function positioner:

-PD: position controller

-PID: process controller

Easy assembly/disassembly by loosening the clamp.

Standard connections: Clamp OD.

Traceability of components.

Equal percentage regulation shaft

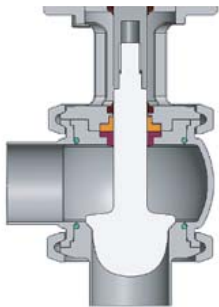

I Materials

Parts in contact with the product	AISI 316L
Other stainless steel parts	AISI 304
Gaskets	EPDM according to FDA 177.2600
Internal surface finish	Ra ≤ 0,5 µm
External surface finish	bright polish



I Options

- Steam barrier (if shaft sterilisation is required).
- Jacketed body.
- Larger actuator sizes.
- Gaskets: NBR or FPM.
- Connections: weld.
- Material and surface roughness certificates.

I Technical specifications

Available sizes	DN 1" - DN 4"	
Working temperature	-10 °C to +121 °C (EPDM)	14 °F to 250 °F
	+140 °C (SIP, max. 30 min)	284 °F
Max. working pressure	10 bar	145 PSI
Compressed air pressure	6-8 bar	87-116 PSI
Air supply connections	G1/8" (BSP)	
Voltage	24 V DC	
Signal	4...20 mA	
	0...10 V (optional)	

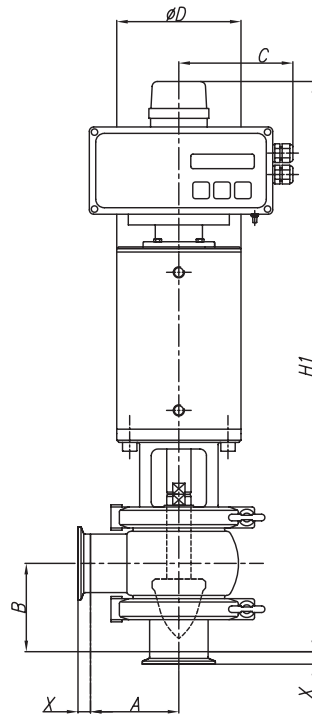

DN	A	B	C	D	H1	X
DN-1"	50	55	105	86	425	13
DN-1 1/2"	60	65		86	440	
DN-2"	70	80		112	500	
DN-2 1/2"	80	90		145	610	
DN-3"	90	100		145	625	
DN-4"	125	120		168	690	



F1phNLR.1.EN-0308

The information contained in this brochure is for guidance only. We reserve the right to modify any material or feature without notice in advance. For further information, please, consult our web site. www.inoxpa.com



I Dimensioning

In the case of the pressure regulation, it is necessary to indicate the range of the pressure to regulate (inlet/outlet pressure) and the valve inlet flow.
 In the case of the flow regulation, it is necessary to indicate the flow range to regulate (valve outlet) and the valve inlet pressure.

The NLR is an equal percentage flow characteristic valve.

The Kv factor is usually used to calculate the dimensions of this kind of valves, the factor allow us to relate the pressure drop and the flow.

The Kv factor is defined as the flow of water through a valve in cubic meters per hour with a pressure drop of 1 bar (see table below).

VALVE DIAMETER	Kv (m³/h) 100% opening	Kv (m³/h) 50% opening
DN-25	13	6
DN-40	31	15
DN-50	59	20
DN-65	87	33
DN-80	140	48
DN-100	178	59
DN-1"	9	4
DN-1 ½"	24	10
DN-2"	48	19
DN-2 ½"	71	26
DN-3"	106	39



The Kv is calculated for water at 5-30°C.

The required Kv (Kv_R) for products with low viscosity and density can be calculated by means of this formula:
 $Kv_R = Q / \sqrt{\Delta P}$ (for viscous products, consult the technical department).

Q (required flow in m³/h)
 ΔP (pressure drop in bar: inlet pressure minus outlet pressure)

The selected Kv (Kv_S) index must be higher than the required Kv_R to ensure a sufficient margin for control.
 Thus, a safety factor is applied by means of the formula: $Kv_S = Kv_R / 0,7$.

Example:

$Q = 15 \text{ m}^3/\text{h}$ $\Delta P = 1 \text{ bar}$
 $Kv_R = Q / \sqrt{\Delta P} = 15$
 $Kv_S = Kv_R / 0,7 = 21,43$ →

According to the result, the most adequate valve is the DN 40 with the maximum index of 31 m³/h (Kv at 100% opening).
 In inches, the most adequate valve is the DN 1 ½".

For calculation in other units: $Cv = 1.16 \times Kv$ (gallon/minute and psi)

NB: Remember that the NLR valve is not a shut-off valve and its code includes neither positioner nor potentiometer.

