



**I Application**

The NLM shut-off valve is a manually actuated single seat valve designed for the applications where automation is not required. It is also used as a regulating valve (with a parabolic plug). Due to the sanitary design, the valves are indicated for the dairy and food-processing industries, beverage production, pharmaceutical and fine chemicals industries.

**I Operating principle**

The NLM valves are actuated by means of a handle that enables to gradually open or close the plug.

**I Design and features**

Available versions: - shut-off valve  
- divert valve

Position locking nut.  
360° adjustable body.  
Sanitary design according to the 3A specifications.  
Connections: weld (mm or inches).

**I Materials**

Parts in contact with the product	AISI 316L
Other stainless steel parts	AISI 304
Gaskets	EPDM according to FDA 177.2600
Internal surface finish	Ra ≤ 0,8µm
External surface finish	bright polish

Option: parabolic plug

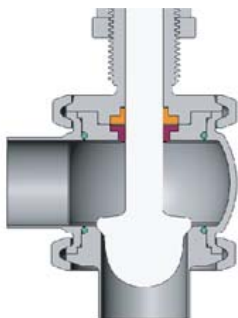

**I Options**

Steam barrier (if shaft sterilisation is required).  
Jacketed body.  
Parabolic plug (regulating valve).  
Internal surface finish: Ra ≤ 0,5 µm.  
Gaskets: NBR or FPM.  
Connections: DIN, Clamp, SMS, RJT, FIL-IDF.



**I Technical specifications**

Available sizes	DN 25 - DN 100	DN 1" - DN 4"
Operating temperature	-10 °C to +120 °C (EPDM)	14 °F to 248 °F
	+140 °C (SIP, max. 30 min)	284 °F
Max. operating pressure	10 bar	

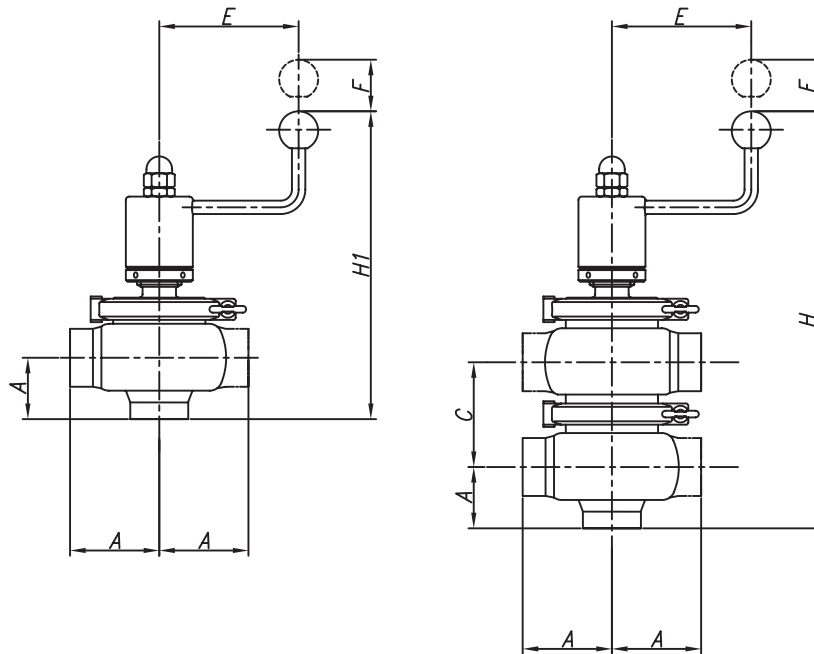

DN	A	C	E	F <sub>min</sub>	H	H1
25	1"	50	125	22	295	240
40	1 1/2"	60		22	325	255
50	2"	70		32	345	265
65	2 1/2"	80		36	385	285
80	3"	90		36	420	305
100	4"	125		40	485	345



The information contained in this brochure is for guidance only. We reserve the right to modify any material or feature without notice in advance. For further information, please, consult our web site. [www.inoxpa.com](http://www.inoxpa.com)



FT.NLM.2-EN-0208