

I Application

The NLF valve is a pneumatically actuated single seat valve designed for assembly at the bottom of the tanks in the dairy, food-processing industries, beverage production, pharmaceutical and fine chemicals industries.

I Operating principle

The seat valves are actuated by a single- or double-acting actuator. The shaft is actuated by the supplied compressed air and opens or closes the valve. Possible configuration of the valve: the valve seat opens into the valve to avoid accidental openings in case of overpressure in the line and to avoid possible contact with the product recovery scrapers.

I Design and features

Sanitary design according to the 3A specifications.
 Total drainage prevents the stagnation of the product.
 Normally closed valve (closed by spring) – standard version.
 Normally open valve (opened by spring) by a simple turn of the pneumatic actuator.
 The valve seat opens into the tank to avoid accidental openings in case of excessive pressure in the tank.
 360° adjustable body, even after welding the flange to the tank.
 Open lantern for visual inspection of the shaft sealing.
 Easy disassembly by loosening the clamp.

I Materials

Parts in contact with the product	AISI 316L
Other stainless steel parts	AISI 304
Gaskets	EPDM according to FDA 177.2600
Internal surface finish	Ra ≤ 0,8 µm
External surface finish	Bright polish



I Options

- Manual actuation.
- Steam barrier (if shaft sterilisation is required).
- C-TOP control unit.
- Jacketed body.
- Larger actuator sizes.
- Internal surface finish: $Ra \leq 0,5 \mu m$.
- Gaskets: NBR or FPM.
- Connections: DIN, Clamp, SMS, RJT, FIL-IDF, etc.
- Double-acting actuator.
- "Twin-Stop" actuator.
- External position sensors.

I Technical specifications

Available sizes	DN 25 - DN 100	DN 1" - DN 4"
Working temperature	-10 °C to +120 °C (EPDM)	14 °F to 248 °F
	+140 °C (SIP, max. 30 min)	284 °F
Max. working pressure	10 bar	145 PSI
Compressed air pressure	6-8 bar	87-116 PSI
Air supply connections	G1/8" (BSP)	

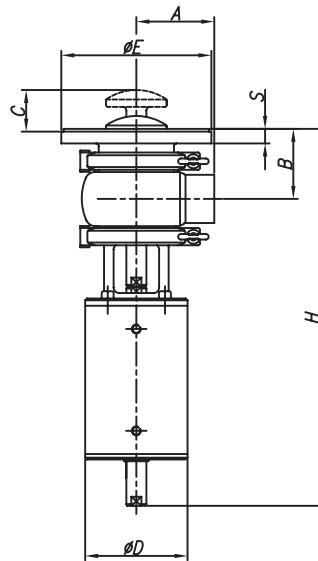

DN	A	B	C	D	E	S	H	
25	1"	50	65	30	86	155	16	312
40	1½"	60	70	30	86	155	16	323
50	2"	70	80	46	112	165	16	406
65	2½"	80	90	50	112	195	16	423
80	3"	90	100	52	112	215	18	446
100	4"	125	120	62	216	255	20	576



The information contained in this brochure is for guidance only. We reserve the right to modify any material or feature without notice in advance. For further information, please, consult our web site.

www.inoxpa.com



FT/NLF3-EN-0310