



Applications

The PIG system is ideal for the recovery of any product remaining in a pipeline in the end of the transfer process. As this product can be of a high value the PIG system recovers the product removing it from the pipelines and preparing the pipeline for a CIP process. Another benefit is the reduction of the fluid sent to the sewage treatment plant that results in saving energy and water.

The main application of the system is viscous media. Among the products treated there are chocolates, marmelades, confectionary creams in the food-processing industry, or gels, creamers and other body care products of high value in the cosmetic industry.

Operating principle

The system comprises a launcher, a receiver, a PIG (or a sphere), two position detectors (one for the launcher and the other for the receiver), four automatic butterfly valves and 2 KH multi-way valves.

The basic principle is that the sphere is put to the launch position. Then the sphere is driven by a propellant (normally compressed air) down the pipeline to the receiver, thus recovering any product left in the pipeline. When recovery is complete, the PIG is situated at the receiver and the system can be cleaned, the PIG can also be cleaned during the normal CIP routine. Upon completion of the CIP process the sphere is located in the launcher, leaving the plant ready for the next production run.

Design and features

Standard system: SIL PIG.

Hygienic system.

High level of product recovery.

PIG can pass through 1.5D bends.

Connections: DIN (standard).

Size ranges: DN40 (1 1/2") to DN80 (3").

Materials

Metallic product contact surfaces	AISI-316 L
Other metal parts	AISI-304
PIG	Silicone
Gaskets	EPDM

Options

Connections: RJT, SMS, clamp, flanges...

Spheres: EPDM, Nitrile, Neoprene and Viton®.

Gaskets: Silicone, NBR, PTFE, Viton®.

STERIPIG system.

Manual system (launch and/or reception)

Various levels of automation.

Control panel.

Option: STERIPIG



I Technical specifications

Max. temperature	120°C
Max. operating pressure	10 bar
Air pressure	5-7 bar
Indicators, switches and solenoids	24 VDC

I Benefits / Advantages

- Production downtime reduced.
- Raw material loss reduced.
- Recovery of up to 98% of the product.
- Effluent reduced.
- CIP cleaning time, water consumption and quantity of chemical products reduced.

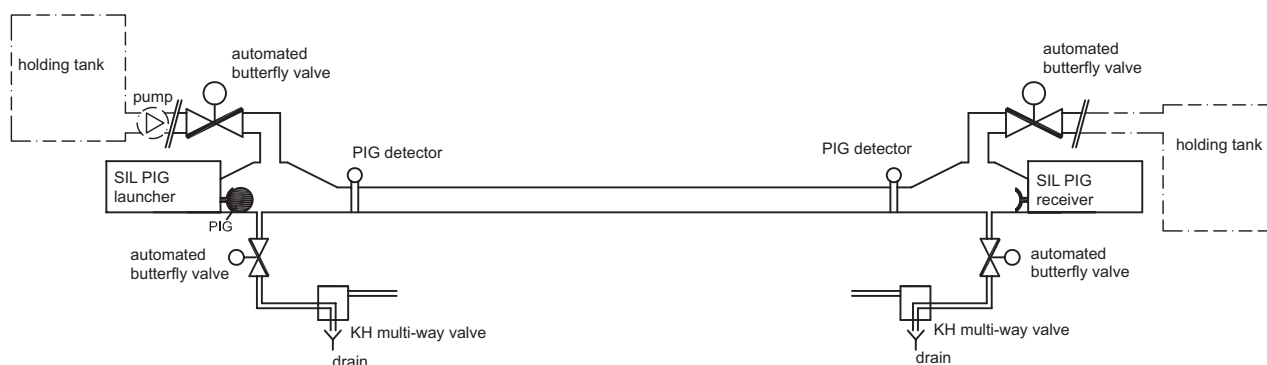

I SIL PIG dimensions

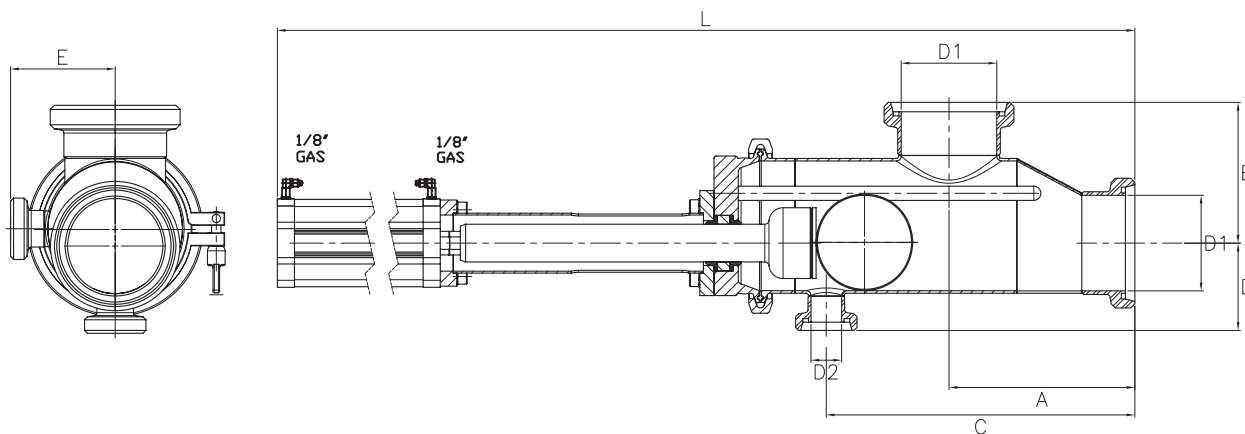

DN	D1	D2	A	B	C	D	E	L*
40	38	26	116	91	173	52	74	588
50	50	26	104	87	168	58	74	589
65	66	26	159	122	255	67	89	836
80	81	26	156	105	262	75	89	839

DN	D1	D2	A	B	C	D	E	L*
1 1/2"	34.8	22.1	115	88	169	50	74	586
2"	47.5	22.1	104	80	167	56	74	585
2 1/2"	60.2	22.1	159	113	250	64	88	822
3"	72.9	22.1	114	107	245	70	88	824

*L can vary depending on the actuator. The length indicated is with the INOXPA standard actuator.

