

Magnetic agitator

I Materials

Rotor	AISI 316L
Welding plate	AISI 316L
Bearing	TungC
Surface finish	Ra < 0,5

I Options

- Bearing: SiC.
- Parts in contact with the media:
special materials (904L, PVDF, Hastelloy...).
- Electropolished.
- Speed sensor.
- Control panel.



I Technical specifications

Max. mixing volume	30000 l
Max. working viscosity	1000 Cp
Max. working speed	450 rpm

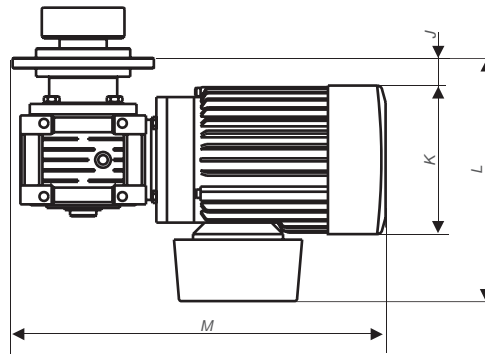
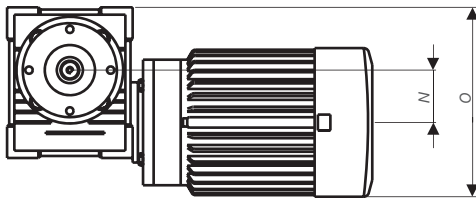

Rotor

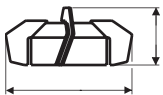

Welding plate

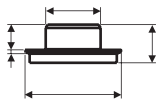

Bearing



	SNO 85/100	SNO 85/140	SNO 120/150	SNO 120/190	SNO 120H/220	SNO 210/275
Rotor						
A	114	145	163	201	220	275
B	71	71	103	110	145	140
Bearing						
C	17		34		35	50
D	23		50,5		53	85
Welding plate						
E	54		85		85	168
F	90		149		150	280
G	48		59		85	72
H	28		39		65	52
I	5		6		5	5
Motor	180W AC		750W AC	1100W AC	1500W AC	2200W AC
J	7		9	8	8	24
K	120		158	178	178	198
L	154		200	219	219	259
M	275		357	410	410	607
N	30		50	63	63	75
O	130		189	224	224	260



The information contained in this brochure is for guidance only. We reserve the right to modify any information or feature without notice in advance. For further information, please, consult our web site. www.inoxpa.com

