

CODO 90° SOLDAR
 WELDING BEND 90°
 COUDE 90° A SOUDER

FIG.2100

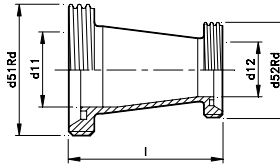

REDUC.CONCÉNTRICA M/M
 CONCENTRIC REDUCER M/M
 REDUCTION CONCEN. F/F

FIG.1311

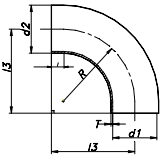

CODO 90° S/MANDRINAR
 EXPANDING WELD. BEND 90°
 COUDE 90° S. A DUDGEONNER

FIG.2000

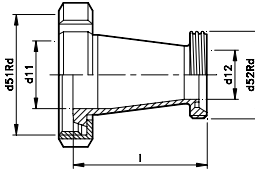

REDUC.CONCÉNTRICA T/M
 CONCENTRIC REDUCER N/M
 REDUCTION CONCEN. E/F

FIG.1331

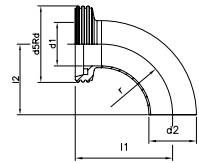

CODO 90° M/S
 BEND 90° M/W
 COUDE 90° F/S

FIG.2110

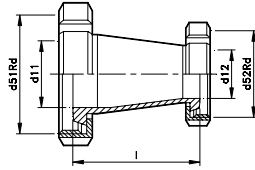

REDUC.CONCÉNTRICA T/T
 CONCENTRIC REDUCER N/N
 REDUCTION CONCEN. E/E

FIG.1333

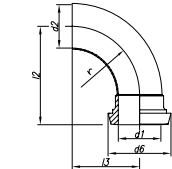

CODO 90° S/C
 BEND 90° W/L
 COUDE 90° S/D

FIG.2120

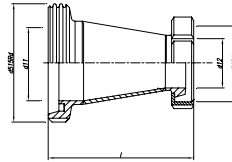

REDUC.CONCÉNTRICA M/T
 CONCENTRIC REDUCER M/N
 REDUCTION CONCEN. F/E

FIG.1313

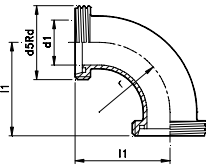

CODO 90° M/M
 BEND 90° M/M
 COUDE 90° M/M

FIG.2111

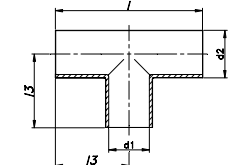

TE SOLDAR
 WELDING TEE
 TE A SOUDER

FIG.3000

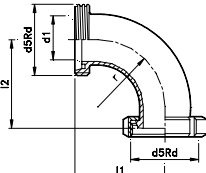

CODO 90° M/T
 BEND 90° M/N
 COUDE 90° F/E

FIG.2113

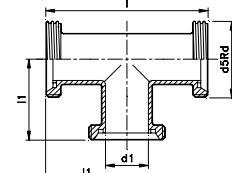

TE M/M/M
 TEE M/M/M
 TE F/F/F

FIG.3111

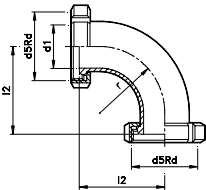

CODO 90° T/T
 BEND 90° N/N
 COUDE 90° E/E

FIG.2133

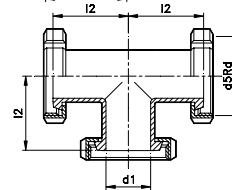

TE T/T/T
 TEE N/N/N
 TE E/E/E

FIG.3333

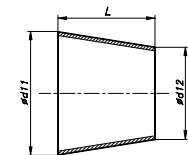

REDUCCIÓN CONCÉNTRICA
 CONCENTRIC REDUCER
 REDUCTION CONCENTRIQUE

FIG.1300

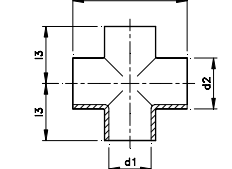

CRUZ SOLDAR
 WELDING CROSS
 CROIX A SOUDER

FIG.30000

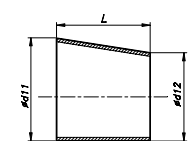

REDUCCIÓN EXCÉNTRICA
 EXCENTRIC REDUCER
 REDUCTION EXCENTRIQUE

FIG.1340

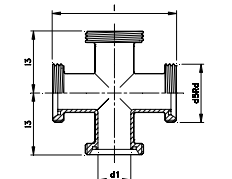

CRUZ M/M/M
 CROSS M/M/M
 CROIX F/F/F

FIG.31111

>> ACCESORIOS DIN
>> ACCESSORIES DIN
>> ACCESSOIRES DIN

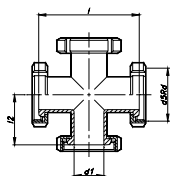

CRUZ T/T/T
CROSS N/N/N
CROIX E/E/E

FIG.33333

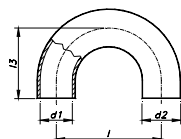

CURVA 180° SOLDAR
WELD.BEND 180°
COUDE 180° A SOUDER

FIG.2800

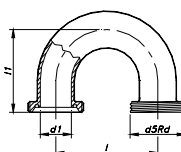

CURVA 180° M/M
BEND 180° M/M
COUDE 180° M/M

FIG.2811

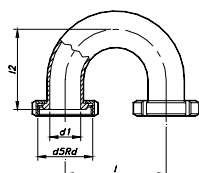

CURVA 180° T/T
BEND 180° N/N
COUDE 180° E/E

FIG.2833

CODO 90° SOLDAR
 WELDING BEND 90°
 COUDE 90° A SOUDER

DN	d1	d2	I3	r	AISI 304	AISI 316L
10	9	12	26	26	2100010	22100010
15	15	18	35	35	2100015	22100015
20	19	22	40	40	2100020	22100020
25	25	28	50	50	2100025	22100025
32	31	34	55	55	2100032	22100032
40	37	40	60	60	2100040	22100040
50	49	52	70	70	2100050	22100050
65	66	70	80	80	2100065	22100065
80	81	85	90	90	2100080	22100080
100	100	104	100	100	2100100	22100100
125	125	129	187,5	187,5	2100125	22100125
150	150	154	225	225	2100150	22100150

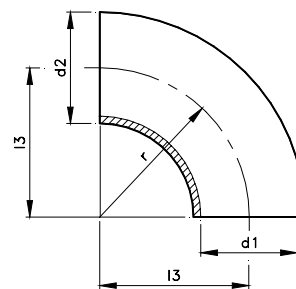

Fig.2100

CODO 90° SOLDAR/MANDRINAR
 EXPANDING WELD.BEND 90°
 COUDE 90° A SOUDER/DUDGEONNER

DN	d1	d2	I	I3	r	T	AISI 304	AISI 316L
10	9	12	12	38	26	1,5	2000010	22000010
15	15	18	12	47	35	1,5	2000015	22000015
20	19	22	12	52	40	1,5	2000020	22000020
25	25	28	20	70	50	1,5	2000025	22000025
32	31	34	23	78	55	1,5	2000032	22000032
40	37	40	25	85	60	1,5	2000040	22000040
50	49	52	27	97	70	1,5	2000050	22000050
65	66	70	30	110	80	2	2000065	22000065
80	81	85	28	118	90	2	2000080	22000080
100	100	104	40	140	100	2	2000100	22000100

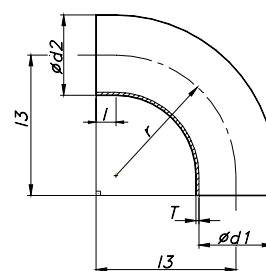

Fig.2000

CODO 90° M/S
 BEND 90° M/W
 COUDE 90° F/S

DN	d1	d2	d5Rd	I1	I2	r	AISI 316L
10	9	12	28x1/8"	43	26	26	22110010
15	15	18	34x1/8"	52	35	35	22110015
20	19	22	44x1/6"	59	40	40	22110020
25	25	28	52x1/6"	72	50	50	22110025
32	31	34	58x1/6"	77	55	55	22110032
40	37	40	65x1/6"	82	60	60	22110040
50	49	52	78x1/6"	93	70	70	22110050
65	66	70	95x1/6"	105	80	80	22110065
80	81	85	110x1/4"	115	90	90	22110080
100	100	104	130x1/4"	130	100	100	22110100

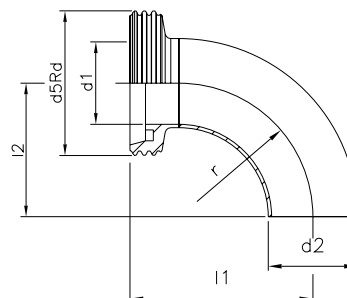

Fig.2110

- Consultar disponibilidad.
- To consult availability.
- Consulter disponibilité.

CODO 90° S/C
 BEND 90° W/L
 COUDE 90° S/D

DN	d1	d2	d6	I2	I3	r	AISI 316L
10	10	12	22,5	39	26	26	22120010
15	16	18	28,5	48	35	35	22120015
20	20	22	36,5	53	40	40	22120020
25	26	28	44	65	50	50	22120025
32	32	34	50	70	55	55	22120032
40	38	40	56	75	60	60	22120040
50	50	52	68,5	86	70	70	22120050
65	66	70	86	97	80	80	22120065
80	81	85	100	107	90	90	22120080
100	100	104	121	120	100	100	22120100

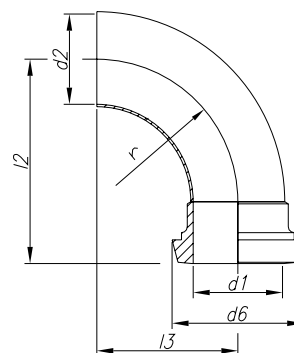

Fig.2120

- Consultar disponibilidad.
- To consult availability.
- Consulter disponibilité.

CODO 90° M/M
 BEND 90° M/M
 COUDE 90° F/F

DN	d1	d5Rd	I1	r	AISI 316L
10	9	28x1/8"	43	26	22111010
15	15	34x1/8"	52	35	22111015
20	19	44x1/6"	59	40	22111020
25	25	52x1/6"	72	50	22111025
32	31	58x1/6"	77	55	22111032
40	37	65x1/6"	82	60	22111040
50	49	78x1/6"	93	70	22111050
65	66	95x1/6"	105	80	22111065
80	81	110x1/4"	115	90	22111080
100	100	130x1/4"	130	100	22111100

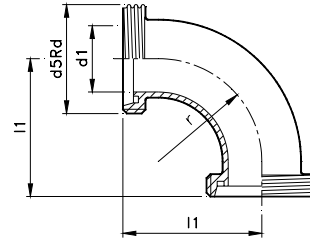

Fig.2111

- Consultar disponibilidad.
- To consult availability.
- Consulter disponibilité.

CODO 90° M/T
 BEND 90° M/N
 COUDE 90° F/E

DN	d1	d5Rd	I1	I2	r	AISI 316L
10	9	28x1/8"	43	43	26	22113010
15	15	34x1/8"	52	52	35	22113015
20	19	44x1/6"	59	58	40	22113020
25	25	52x1/6"	72	72	50	22113025
32	31	58x1/6"	77	80	55	22113032
40	37	65x1/6"	82	86	60	22113040
50	49	78x1/6"	93	98	70	22113050
65	66	95x1/6"	105	112	80	22113065
80	81	110x1/4"	115	127	90	22113080
100	100	130x1/4"	130	144	100	22113100

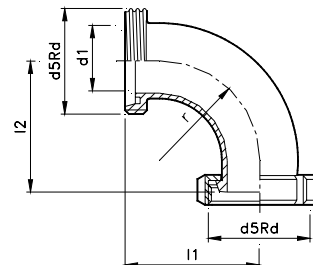

Fig.2113

- Consultar disponibilidad.
- To consult availability.
- Consulter disponibilité.

>> ACCESORIOS DIN
 >> ACCESSORIES DIN
 >> ACCESSOIRES DIN

CODO 90° T/T
 BEND 90° N/N
 COUDE 90° E/E

DN	d1	d5Rd	I2	r	AISI 316L
10	10	28x1/8"	43	26	22133010
15	16	34x1/8"	52	35	22133015
20	20	44x1/6"	58	40	22133020
25	25	52x1/6"	72	50	22133025
32	31	58x1/6"	80	55	22133032
40	37	65x1/6"	86	60	22133040
50	49	78x1/6"	98	70	22133050
65	66	95x1/6"	112	80	22133065
80	81	110x1/4"	127	90	22133080
100	100	130x1/4"	144	100	22133100

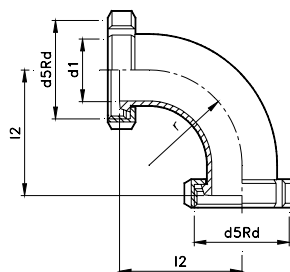
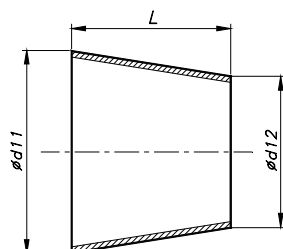

Fig.2133

- Consultar disponibilidad.
- To consult availability.
- Consulter disponibilité.

REDUCCION CONCÉNTRICA SOLDAR
 WELDING CONCENTRIC REDUCER
 REDUCTION CONCENTRIQUE A SOUDER

FIG.1300



REDUCCION EXCÉNTRICA SOLDAR
 WELDING EXCENTRIC REDUCER
 REDUCTION EXCENTRIQUE A SOUDER

FIG.1340

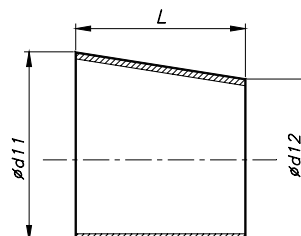

DN	Ød11	Ød12	L	AISI 316L
15-10	18	12	10	21300006
20-15	22	18	7	21300007
25-15	28	18	18	21300008
25-20	28	22	11	21300009
32-20	34	22	22	21300012
32-25	34	28	11	21300011
40-20	40	22	33	21300014
40-25	40	28	22	21300016
40-32	40	34	11	21300021
50-25	52	28	44	21300024
50-32	52	34	33	21300026
50-40	52	40	22	21300033
65-32	70	34	62	21300039
65-40	70	40	51	21300041
65-50	70	52	29	21300051
80-40	85	40	78	21300064
80-50	85	52	56	21300066
80-65	85	70	27	21300081
100-50	104	52	90	21300099
100-65	104	70	61	21300101
100-80	104	85	34	21300126

DN	Ød11	Ød12	L	AISI 316L
20-15	22	18	7	21340007
25-15	28	18	18	21340008
25-20	28	22	11	21340009
32-20	34	22	22	21340012
32-25	34	28	11	21340011
40-25	40	28	22	21340016
40-32	40	34	11	21340021
50-25	52	28	44	21340024
50-32	52	34	33	21340026
50-40	52	40	22	21340033
65-40	69	40	51	21340041
65-50	69	52	29	21340051
80-40	84	40	78	21340064
80-50	84	52	56	21340066
80-65	84	69	27	21340081
100-65	104	69	61	21340101
100-80	104	84	34	21340126

Las dimensiones pueden variar en función de su fabricación.
 Consultar INOXPA (inoxpa@inoxpa.com, Tel. 902 450 090)

REDUCCION CONCÉNTRICA M/M
CONCENTRIC REDUCER M/M
REDUCTION CONCENTRIQUE F/F

DN	d11	d12	d51Rd	d52Rd	L	AISI 316L
32-25	32	26	58x1/6"	52x1/6"	55	21311011
40-25	38	26	65x1/6"	52x1/6"	66	21311016
40-32	38	32	65x1/6"	58x1/6"	55	21311021
50-32	50	32	78x1/6"	58x1/6"	78	21311026
50-40	50	38	78x1/6"	65x1/6"	67	21311033
65-40	66	38	95x1/6"	65x1/6"	98	21311041
65-50	66	50	95x1/6"	78x1/6"	77	21311051
80-50	81	50	110x1/4"	78x1/6"	104	21311066
80-65	81	66	110x1/4"	95x1/6"	77	21311081
100-65	100	66	130x1/4"	95x1/6"	116	21311101
100-80	100	81	130x1/4"	110x1/6"	89	21311126

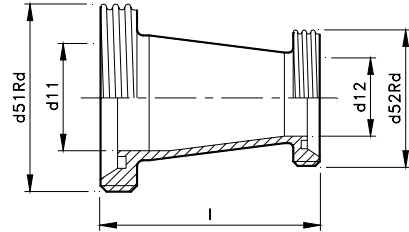

Fig.1311

- Consultar disponibilidad.
- To consult availability.
- Consulter disponibilité.

Las dimensiones pueden variar en función de su fabricación.
Consultar INOXPA (inoxpa@inoxpa.com, Tel. 902 450 090)

REDUCCION CONCÉNTRICA T/M
CONCENTRIC REDUCER N/M
REDUCTION CONCENTRIC E/F

DN	d11	d12	d51Rd	d52Rd	L	AISI 316L
32-25	32	26	58x1/6"	52x1/6"	48	21331011
40-25	38	26	65x1/6"	52x1/6"	59	21331016
40-32	38	32	65x1/6"	58x1/6"	48	21331021
50-32	50	32	78x1/6"	58x1/6"	71	21331026
50-40	50	38	78x1/6"	65x1/6"	60	21331033
65-40	66	38	95x1/6"	65x1/6"	90	21331041
65-50	66	50	95x1/6"	78x1/6"	69	21331051
80-50	81	50	110x1/4"	78x1/6"	96	21331066
80-65	81	66	110x1/4"	95x1/6"	70	21331081
100-65	100	66	130x1/4"	95x1/6"	106	21331101
100-80	100	81	130x1/4"	110x1/4"	79	21331126

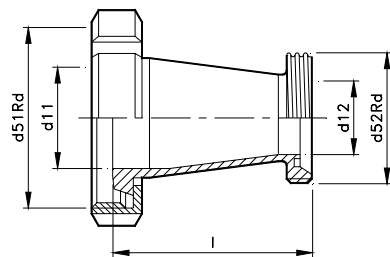

Fig.1331

- Consultar disponibilidad.
- To consult availability.
- Consulter disponibilité.

Las dimensiones pueden variar en función de su fabricación.
Consultar INOXPA (inoxpa@inoxpa.com, Tel. 902 450 090)

REDUCCION CONCENTRICA T/T
CONCENTRIC REDUCER N/N
REDUCTION CONCENTRIQUE E/E

DN	d11	d12	d51Rd	d52Rd	L	AISI 316L
32-25	32	26	58x1/6"	52x1/6"	41	21333011
40-25	38	26	65x1/6"	52x1/6"	52	21333016
40-32	38	32	65x1/6"	58x1/6"	41	21333021
50-32	50	32	78x1/6"	58x1/6"	64	21333026
50-40	50	38	78x1/6"	65x1/6"	53	21333033
65-40	66	38	95x1/6"	65x1/6"	83	21333041
65-50	66	50	95x1/6"	78x1/6"	62	21333051
80-50	81	50	110x1/4"	78x1/6"	89	21333066
80-65	81	66	110x1/4"	95x1/6"	61	21333081
100-65	100	66	130x1/4"	95x1/6"	98	21333101
100-80	100	81	130x1/4"	110x1/4"	71	21333126

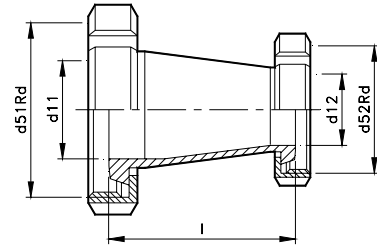

Fig.1333

- Consultar disponibilidad.
- To consult availability.
- Consulter disponibilité.

Las dimensiones pueden variar en función de su fabricación.
Consultar INOXPA (inoxpa@inoxpa.com, Tel. 902 450 090)

REDUCCION CONCENTRICA M/T
CONCENTRIC REDUCER M/N
REDUCTION CONCENTRIQUE F/E

DN	d11	d12	d51Rd	d52Rd	L	AISI 316L
32-25	32	26	58x1/6"	52x1/6"	48	21313011
40-25	38	26	65x1/6"	52x1/6"	59	21313016
40-32	38	32	65x1/6"	58x1/6"	48	21313021
50-32	50	32	78x1/6"	58x1/6"	71	21313026
50-40	50	38	78x1/6"	65x1/6"	60	21313033
65-40	66	38	95x1/6"	65x1/6"	91	21313041
65-50	66	50	95x1/6"	78x1/6"	70	21313051
80-50	81	50	110x1/4"	78x1/6"	97	21313066
80-65	81	66	110x1/4"	95x1/6"	69	21313081
100-65	100	66	130x1/4"	95x1/6"	108	21313101
100-80	100	81	130x1/4"	110x1/4"	81	21313126

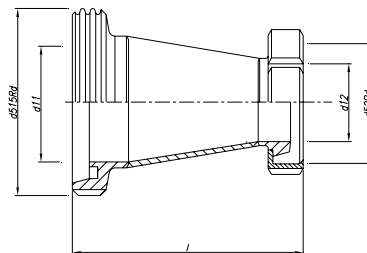

Fig.1313

- Consultar disponibilidad.
- To consult availability.
- Consulter disponibilité.

Las dimensiones pueden variar en función de su fabricación.
Consultar INOXPA (inoxpa@inoxpa.com, Tel. 902 450 090)

TE SOLDAR
 WELDING TEE
 TE A SOUDER

DN	d1	d2	I3	I	AISI 304	AISI 316L
10	9	12	26	52	3000010	23000010
15	15	18	35	70	3000015	23000015
20	19	22	40	80	3000020	23000020
25	25	28	50	100	3000025	23000025
32	31	34	55	110	3000032	23000032
40	37	40	60	120	3000040	23000040
50	49	52	70	140	3000050	23000050
65	66	70	80	160	3000065	23000065
80	81	85	90	180	3000080	23000080
100	100	104	100	200	3000100	23000100
125	125	129	187,5	375	3000125	23000125
150	150	154	225	450	3000150	23000150

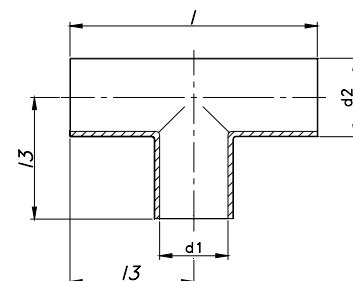

Fig.3000

TE M/M/M
 TEE M/M/M
 TE F/F/F

DN	d1	d5Rd	I1	I	AISI 304	AISI 316L
10	9	28x1/8"	43	86	3111010	23111010
15	15	34x1/8"	52	104	3111015	23111015
20	19	44x1/6"	59	118	3111020	23111020
25	25	52x1/6"	72	144	3111025	23111025
32	31	58x1/6"	77	154	3111032	23111032
40	37	65x1/6"	82	164	3111040	23111040
50	49	78x1/6"	93	186	3111050	23111050
65	66	95x1/6"	105	210	3111065	23111065
80	81	110x1/4"	115	230	3111080	23111080
100	100	130x1/4"	130	260	3111100	23111100

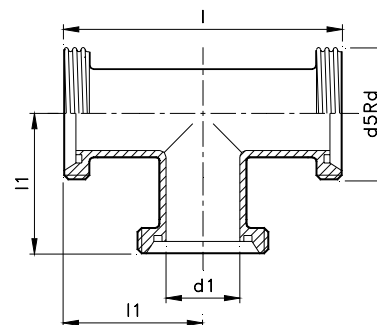

Fig.3111

- Consultar disponibilidad.
- To consult availability.
- Consulter disponibilité.

>> ACCESORIOS DIN
 >> ACCESSORIES DIN
 >> ACCESSOIRES DIN



TE T/T/T
 TEE N/N/N
 TE E/E/E

DN	d1	d5Rd	I2	AISI 304	AISI 316L
10	9	28x1/8"	39	3333010	23333010
15	15	34x1/8"	48	3333015	23333015
20	19	44x1/6"	53	3333020	23333020
25	25	52x1/6"	65	3333025	23333025
32	31	58x1/6"	70	3333032	23333032
40	37	65x1/6"	75	3333040	23333040
50	49	78x1/6"	86	3333050	23333050
65	66	95x1/6"	97	3333065	23333065
80	81	110x1/4"	107	3333080	23333080
100	100	130x1/4"	120	3333100	23333100

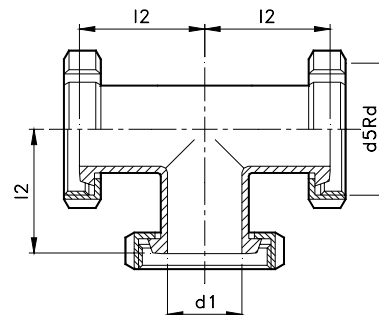

Fig.3333

- Consultar disponibilidad.
- To consult availability.
- Consulter disponibilité.

CRUZ SOLDAR
 WELDING CROSS
 CROIX A SOUDER

DN	d1	d2	I3	I	AISI 316L
10	9	12	26	52	230000010
15	15	18	35	70	230000015
20	19	22	40	80	230000020
25	25	28	50	100	230000025
32	31	34	55	110	230000032
40	37	40	60	120	230000040
50	49	52	70	140	230000050
65	66	70	80	160	230000065
80	81	85	90	180	230000080
100	100	104	100	200	230000100

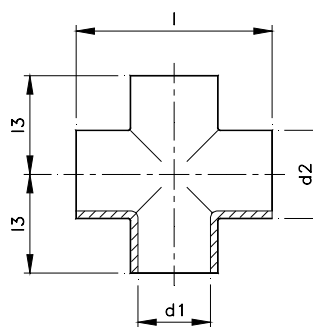

Fig.30000



CRUZ M/M/M/M
 CROSS M/M/M/M
 CROIX F/F/F/F

DN	d1	d5Rd	I3	I	AISI 316L
10	9	28x1/8"	43	86	231111010
15	15	34x1/8"	52	104	231111015
20	19	44x1/6"	59	118	231111020
25	25	52x1/6"	72	144	231111025
32	31	58x1/6"	77	154	231111032
40	37	65x1/6"	82	164	231111040
50	49	78x1/6"	93	186	231111050
65	66	95x1/6"	105	210	231111065
80	81	110x1/4"	115	230	231111080
100	100	130x1/4"	130	260	231111100

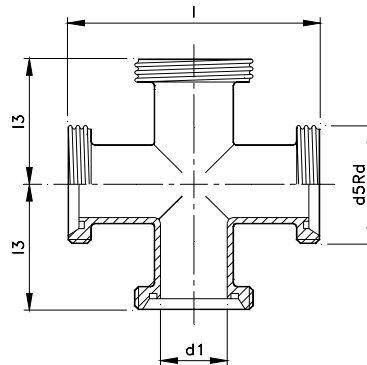

Fig.31111

- Consultar disponibilidad.
- To consult availability.
- Consulter disponibilité.

CRUZ T/T/T/T
 CROSS N/N/N/N
 CROIX E/E/E/E

DN	d1	d5Rd	I2	I	AISI 316L
10	9	28x1/8"	39	78	233333010
15	15	34x1/8"	48	96	233333015
20	19	44x1/6"	53	106	233333020
25	25	52x1/6"	65	130	233333025
32	31	58x1/6"	70	140	233333032
40	37	65x1/6"	75	150	233333040
50	49	78x1/6"	86	172	233333050
65	66	95x1/6"	97	194	233333065
80	81	110x1/4"	107	214	233333080
100	100	130x1/4"	120	240	233333100

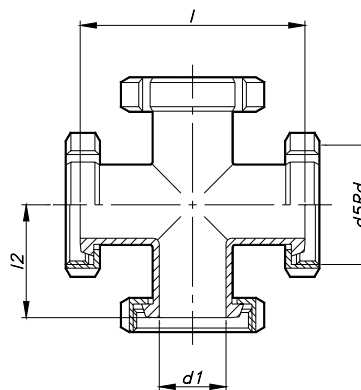

Fig.33333

- Consultar disponibilidad.
- To consult availability.
- Consulter disponibilité.

CURVA 180° SOLDAR
 WELDING BEND 180°
 COUDE 180° SOUDER/DUDGEONNER

DN	d1	d2	I3	I	AISI 316L
10	10	13	26	52	22800010
15	16	19	34	68	22800015
20	20	23	38	76	22800020
25	26	29	50	100	22800025
32	32	35	55	110	22800032
40	38	41	60	120	22800040
50	50	53	70	140	22800050
65	66	70	80	160	22800065
80	81	85	90	180	22800080
100	100	104	100	200	22800100

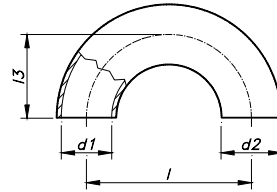

Fig.2800

- Consultar disponibilidad.
- To consult availability.
- Consulter disponibilité.

CURVA 180° M/M
 BEND 180° M/M
 COUDE 180° F/F

DN	d1	d5Rd	I1	I	AISI 316L
10	10	28x1/8"	43	52	22811010
15	16	34x1/8"	51	68	22811015
20	20	44x1/6"	57	76	22811020
25	26	52x1/6"	72	100	22811025
32	32	58x1/6"	77	110	22811032
40	38	65x1/6"	82	120	22811040
50	50	78x1/6"	93	140	22811050
65	66	95x1/6"	105	160	22811065
80	81	110x1/4"	115	180	22811080
100	100	130x1/4"	130	200	22811100

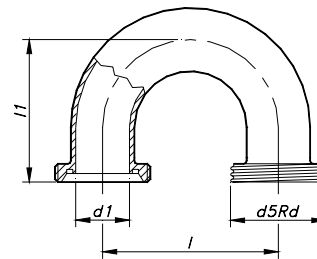

Fig.2811

- Consultar disponibilidad.
- To consult availability.
- Consulter disponibilité.

>> ACCESORIOS DIN
 >> ACCESSORIES DIN
 >> ACCESSOIRES DIN

CURVA 180° T/T
 BEND 180° N/N
 COUDE 180° E/E

DN	d1	d5Rd	I2	I	AISI 316L
10	9	28x1/8"	39	52	22833010
15	15	34x1/8"	47	68	22833015
20	19	44x1/6"	51	76	22833020
25	25	52x1/6"	65	100	22833025
32	31	58x1/6"	70	110	22833032
40	37	65x1/6"	75	120	22833040
50	49	78x1/6"	86	140	22833050
65	66	95x1/6"	97	160	22833065
80	81	110x1/4"	107	180	22833080
100	100	130x1/4"	120	200	22833100

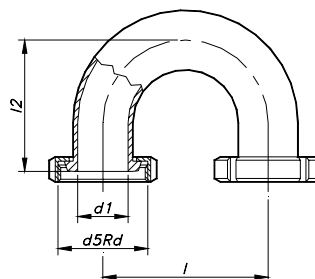

Fig.2833

- Consultar disponibilidad.
- To consult availability.
- Consulter disponibilité.