

# HYGINOX SE

## Centrifugal Pump



### APPLICATION

The sanitary and cost-efficient design of the Hyginox SE centrifugal pump makes it particularly suitable as main process pump in the dairy, beverage, pharmaceutical and cosmetic industries.

### DESIGN AND FEATURES

Hyginox SE is a range of close-coupled centrifugal pumps with sanitary design, compact and efficient. It is made of a cold-formed stainless steel casing, stainless steel open impeller (investment casting), pump cover, lantern and shaft, connected to the motor shaft by mechanical compression.

The pump is equipped with a single mechanical seal in its standard version. When the application needs, the pump can be equipped with a double mechanical seal.

The motor complies with the IEC standards, it is protected with a stainless steel shroud and provided with the height adjustable hygienically designed legs.

### TECHNICAL SPECIFICATIONS

#### Materials

Parts in contact with the product	1.4404 (AISI 316L)
Other steel parts	1.4301 (AISI 304)
Gaskets in contact with the product	EPDM

#### Single mechanical seal

Rotary part	carbon (C)
Stationary part	silicon carbide (SiC)
Gaskets in contact with the product	EPDM

#### Double mechanical seal

Arrangement	tandem
Auxiliary (buffer) liquid consumption	5 - 10 l/h
Maximum working pressure	10 kPa (1 bar)
Maximum working temperature	40°C
Ø connection	G 1/8

#### Surface finish

Internal	polished $Ra \leq 0,8 \mu m$
External	matt



**Connections<sup>1</sup>**

DIN 11851

SMS

Clamp OD

1) other connections available on request

**Operating limits**

Nominal pressure	1000 kPa (10 bar)	145PSI
Temperature range	-10°C to 120°C	14° to 248°F
SIP	140°C (max 30 min)	284°F
Maximum flow	145 m <sup>3</sup> /h	638 US GPM
Maximum differential head	90 m	295 ft
Maximum speed	3500 rpm	

**MOTOR**

Triphasic induction motor with B34 flange (the type of motor will be IECB35 for motor sizes 80 and 90 in Hyginox SE-15 pumps and for motor sizes 132 and 160 for all kinds of pumps), in compliance with the IEC standards, 2 poles = 3000/3600 rpm, efficiency class according to EC regulation, IP 55 protection and F-class insulation.

3 phases, 50 Hz, 230 V Δ / 400 V Y, ≤ 4 kW

3 phases, 50 Hz, 400 V Δ / 690 V Y, ≥ 5,5 kW

**OPTIONS**

Double mechanical seal.

SiC/SiC mechanical seal.

Gaskets: FPM and PTFE.

Jacketed pump housing.

Drain port.

Other connection types.

Motor with other voltages, frequencies, protection classes and efficiencies.

Trolley and/or control panel.

ATEX certification.

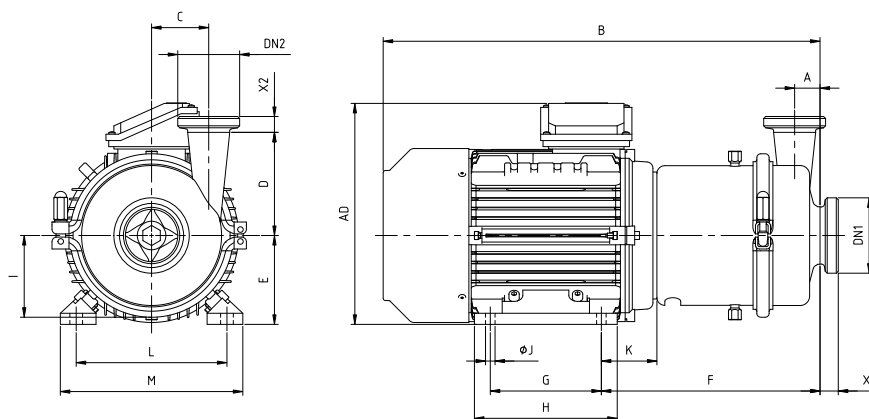
**MB DIMENSIONS**

01.011.32.0049

Pump	DIN 11851					SMS					CLAMP OD				
	DN1	DN2	X <sub>1</sub>	X <sub>2</sub>	D	DN1	DN2	X <sub>1</sub>	X <sub>2</sub>	D	DN1	DN2	X <sub>1</sub>	X <sub>2</sub>	D
SE-15	40	32	26	22	78	38	38	23	23	78	1½"	1½"	14	14	78
SE-20	50	40	23	20	120	51	38	23	23	102	2"	1½"	21	29	102
SE-26	65	50	23	20	130	76	51	27	23	130	2"	1½"	29	15	130
SE-28	40	40	33	27	138	38	38	23	23	108	1½"	1½"	28	29	108
SE-25	65	50	26	24	151	76	51	27	23	134	3"	2"	29	29	134
SE-36	100	65	38	27	155	104	76	30	27	155	4"	3"	22	29	155

Pump	Motor			A	B	C	E	F	G	H	AD	I	ØJ	K	L	M	kg	
	Size	kW	rpm															
SE-15	A	0,25	1450	29	377	55	71	206	90	105	185	80	7	45	112	112	12	
		0,37															13	
		0,55															13	
	B	0,75	2950															18
		1,1					80	235	100	130	215	80	10	50	125	125	20	
		1,5					90	241			235			56	140	140	24	
C	90S	1,5															26	
SE-20	C	1,1	1450	32	452	74	90	245	100	130	235	10	10	56	140	180	25	
		1,5															28	
	90L	2,2	2950						125	155		105					36	
	D	100	3				100	262	140	180	260		12	63	160	200	36	
	E	112	4				112	269			280			70	190	230	43	
SE-26	C	1,1	1450	32	459	72	90	252	100	130	235	10	10	56	140	180	27	
		1,5															26	
		2,2															29	
	D	100	3				100	269			260		105	63	160	200	36	
	E	4	2950							180								43
		5,5							140		280		12	70	190	230	49	
	F	5,5																61
7,5																	70	
SE-28	C	1,1	1450	32	445	106	90	238	100	125	235	10	10	56	140	180	32	
		1,5															32	
		2,2															34	
	D	100	3				100	235			260		137	63	160	200	41	
	E	4	2950							180								48
		5,5							140		280		12	70	190	230	54	
	F	5,5																66
7,5																	75	
SE-35	D	2,2	1450	49	527	104	100	275	140	180	260	137	12	63	160	200	43	
		3															47	
	E	4																55
		5,5						112	282		280			70	190	230	55	
	F	5,5	2950															67
		7,5						132	324	178	230	320	150	12	112	216	260	76
	G	11																89
15																	118	
SE-36	D	2,2	1450	37	516	98	100	264	140	180	260	137	12	63	160	200	45	
		3															50	
	E	4																56
		5,5									280			70	190	230	56	
	F	5,5	2950															64
		7,5						132	313	178	230	320	150	12	112	216	260	79
	G	11																92
15																	120	
																	140	

## MR DIMENSIONS

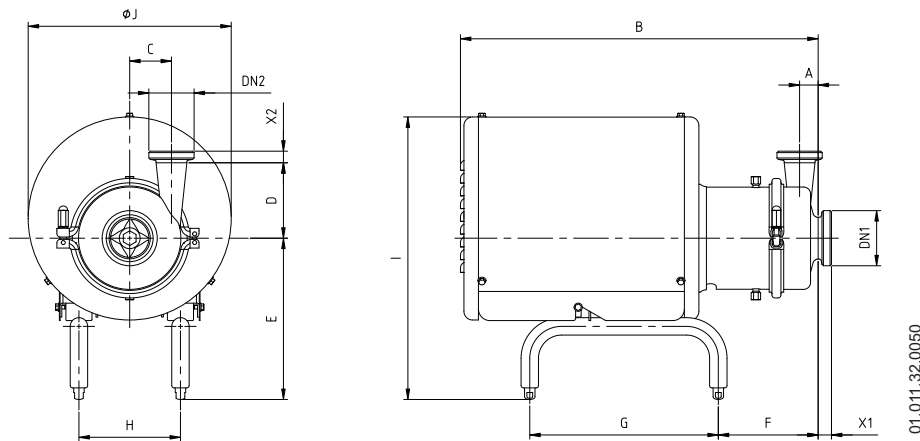

01.011.32.0050

Pump	DIN 11851					SMS					CLAMP OD				
	DN1	DN2	X <sub>1</sub>	X <sub>2</sub>	D	DN1	DN2	X <sub>1</sub>	X <sub>2</sub>	D	DN1	DN2	X <sub>1</sub>	X <sub>2</sub>	D
SE-15	40	32	26	22	78	38	38	23	23	78	1½"	1½"	14	14	78
SE-20	50	40	23	20	120	51	38	23	23	102	2"	1½"	21	29	102
SE-26	65	50	23	20	130	76	51	27	23	130	2"	1½"	29	15	130
SE-28	40	40	33	27	138	38	38	23	23	108	1½"	1½"	28	29	108
SE-25	65	50	26	24	151	76	51	27	23	134	3"	2"	29	29	134
SE-36	100	65	38	27	155	104	76	30	27	155	4"	3"	22	29	155

Pump	Motor			A	B	C	E	F	G	H	I	ØJ	kg	
	Size	kW	rpm											
SE-15	A	0,25	1450	29	443	55	203	116	250	112	350	230	16	
		0,37											17	
		0,55											17	
	B	0,75	2950	32	532	74	217	152	275	132	405	290	290	24
		1,1												26
		1,5												30
SE-20	C	1,1	1450	32	535	74	217	162	275	132	415	290	32	
		1,5											31	
		2,2	2950										33	
	D	100	3	32	610	74	266	160	325	175	480	350	350	45
		112	4											51
		1,1	1450											33
SE-26	C	1,5		32	542	72	227	168	275	132	415	290	32	
		2,2											34	
		3	2950										45	
	D	100	3	32	617	72	266	166	325	175	480	350	350	45
		112	4											52
		5,5												58
F	132	5,5	32	747	72	278	173	325	175	490	490	350	73	
	7,5												81	
	1,1	1450											38	
SE-28	C	1,5		32	528	106	227	154	275	132	415	290	37	
		2,2											39	
		3	2950										50	
	D	100	3	32	605	106	266	151	325	175	480	350	350	57
		112	4											63
		5,5												63
F	132	5,5	32	733	106	278	158	325	175	490	490	350	78	
	7,5												86	
	1,1	1450											38	

Pump	Motor			A	B	C	E	F	G	H	I	ØJ	kg	
	Size	kW	rpm											
SE-35	D	100	2,2	1450	623	104	266	172	325	175	480	350	51	
			3										56	
	E	112	4	2950	753	293	206	375	216	530	400	465	63	
													5,5	64
	F	132	7,5	2950	753	293	206	375	216	530	400	465	78	
													11	100
	G	160	11	2950	888	367	246	475	267	645	465	465	136	
													15	156
	SE-36	D	100	2,2	1450	612	98	266	160	325	175	480	350	54
				3										59
E		112	4	2950	742	293	194	375	216	530	400	465	65	
													5,5	66
F		132	7,5	2950	742	293	194	375	216	530	400	465	80	
													11	103
G		160	11	2950	877	367	246	475	267	645	465	465	138	
													15	158