



I Application

The C-TOP+ is a pneumatic control unit designed to ensure an optimum control over the INOXPA process valves. It is compatible with most PLC (Programmable Logic Controllers) automated systems with digital communication.

C-TOP+ can be installed to any current process valve in the food-processing, beverage and biopharmaceutical industries.

I Operating principle

The C-TOP+ control unit incorporates indication and command devices to control pneumatically operated process valves.

This unit as a single piece has the following features:

- Pneumatic and electric control over the valve
- Position sensors with feedback

The control units are fitted to the pneumatic actuator. It receives signals from a control panel or from a PLC to actuate the valves and sends signals to the PLC or to the control panel to communicate the status/position of the valve.

C-TOP+ unit contains three LEDs (depending on the configuration) constantly indicating the operating status of the valve. A fourth LED (white) indicates whether the operating voltage supply is connected.

White LED	Red LED	Green LED	Yellow LED	Description
○	○	○	○	Operating voltage not applied (no led illuminated)
☀	○	○	○	Operating voltage is applied, no sensor activated
☀	○	●	○	Sensor S1 is activated
☀	●	○	○	Sensor S2 is activated
☀	○	○	☀	Sensor S3 is activated
☀	○	●	☀	Sensor S4 (external) is activated

Design and features

The design of the C-TOP+ unit is simple, modular and resistant that guarantees the maximum flexibility. Depending on the product version it has up to three 3/2 solenoid valves (NC) and three sensors. If necessary, an additional external sensor and an additional external solenoid valve can be connected.

The sensors are actuated contact-free by a magnet attached to the control rod. The sensor can be magnetoresistive or magnetic reed type and it is activated without contact with a magnet in the shaft control.

The C-TOP+ units can be set up according to the customer's requirements.

Configuration of solenoid valves

- Single-acting actuation - 1 solenoid valve
- Double-acting actuation - 2 solenoid valves
- Mixproof valve – 3 solenoid valves

Configuration of sensors

- 1 position (closed or open valve) - 1 sensor
- 2 positions (closed and open valve) - 2 sensors
- 3 positions (open valve, closed valve, Mixproof seat cleaning) - 3 sensors



I Materials

End cap	Polypropylene
Housing	Reinforced polypropylene
Plate	Reinforced polypropylene
Seals	EPDM
Screws	Stainless steel

I Technical specifications

Outdoor use	C1 – weather protected areas
Stroke	≤ 70 mm
Maximum shaft diameter	22 mm
Mounting position	360°
Fastening type	Screw-clamped
Operating medium	Filtered compressed air, grade of filtration 40 µm, lubricated or non lubricated
Measuring principle	Magnetic reed (micro), Bipolar, NO Magneto-resistive (inductive), PNP, NO
Measurement parameter	Position
Visual indicators	LED
Solenoid valves	3/2 way, NC
Operating pressure	3 ... 8 bar
Nominal operating pressure	6 bar
Standard nominal flow rate	200 l/min
Storage temperature	-20 ... 60 °C
Ambient temperature	-5 ... 60 °C
Protection class (in mounted status)	IP65, IP67
Operating voltage DC	24 V DC ± 10%

Pneumatic connections:

Connection 1: compressed air connection for operating pressure QS-8 (Ø8 mm pipe)

Connection 3: exhaust Integrated silencer

Connection A1 ... A3: working lines of the solenoid valves QS-6 (Ø6 mm pipe)

Max. line length 30 m

Electrical connection Terminal CAGE CLAMP (0,2 to 1,5 mm²)
Cable gland PG 16 x 1.5 (Ø10 mm cable)

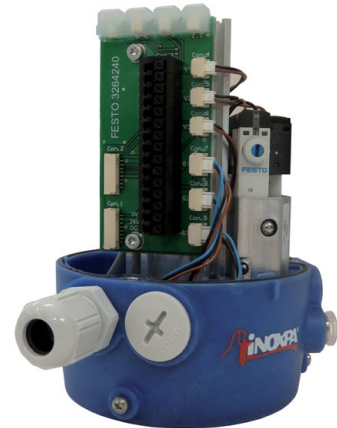

I Electrical connection

Version for managing max. 3+1 solenoid valves and 3+1 sensors

Pin allocation (spring force terminal 1 x 15 pin)

Signal	Printing	
Switching input of PLC 24 V DC valve V1	16	16
Switching input of PLC 24 V DC valve V2	15	15
Switching input of PLC 24 V DC valve V3	14	14
Switching input of PLC 24 V DC valve V4	13	13
Output 24 V DC external valve V4	12	12
Output 0 V DC external valve V4	11	11
Power supply 0 V external sensor S4	10	10
Power supply 24 V DC external sensor S4	9	9
Signal input external sensor S4	8	8
Output sensor 4 / LED yellow + green for PLC	7	7
Output sensor 3 / LED yellow for PLC	6	6
Output sensor 1 / LED green for PLC	5	5
Output sensor 2 / LED red for PLC	4	4
Power supply 0 V DC	0V	2
Power supply 24 V DC	24 V DC	1

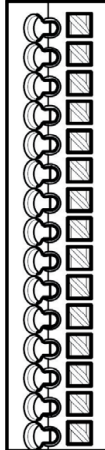

Version for managing max. 2 solenoid valves and 2 sensors

Pin allocation (spring force terminal 1 x 6 pin)

Switching input of PLC 24 VDC valve V1	16	16
Switching input of PLC 24 VDC valve V2	15	15
Output sensor 1/LED green for PLC	5	5
Output sensor 2/LED red for PLC	4	4
Power supply 0 V DC	0V 2	2
Power supply 24 V DC	24 V DC	1

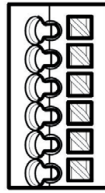

I General dimensions

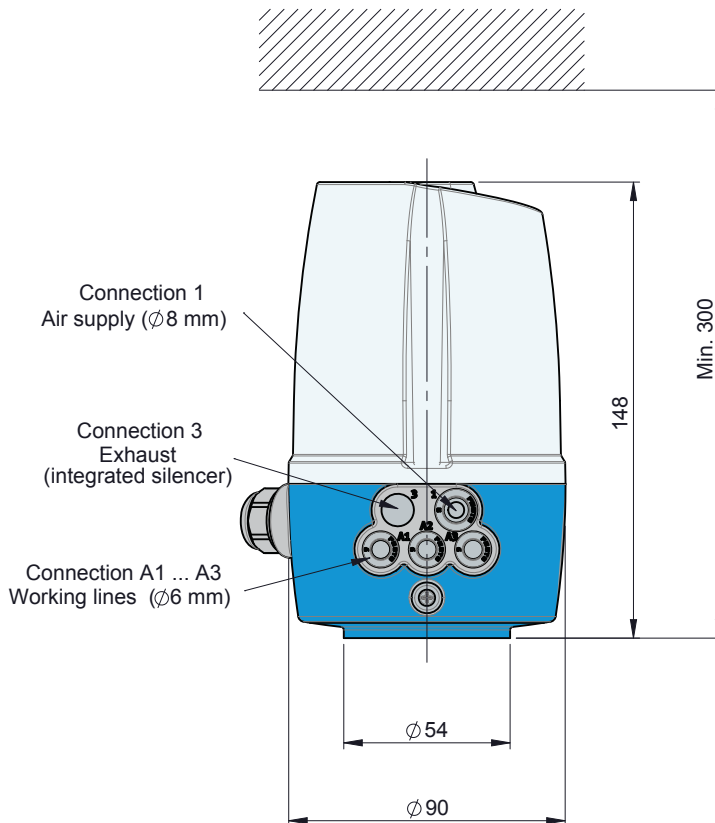
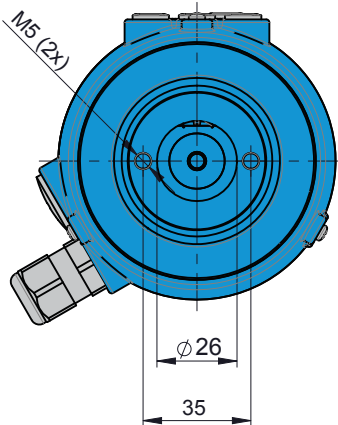

FT-C-TOP+'15.1.EN-0416